

Endoscopic Linear Cutter Reloads

Instruction Manual

	A change from red to blue indicates that sterilization is complete.		MR (Magnetic Resonance) Safe Under Specific Conditions
	Medical Device		Catalogue Number
	The product is provided with a CE marketing in accordance with regulations stated in Regulation(EU)2017/745 concerning Medical Devices.		Hangzhou Mindray Medical Technology Co., Ltd. has been authorized the use of the registered trademark of Shenzhen Mindray Bio-medical Electronics Co., Ltd.

Note

- Before operating this instrument, it is necessary to be familiar with and understand the meanings of the symbols mentioned above.

Product Overview

Structural Composition

Endoscopic Linear Cutter Reloads consists of a cartridge shell, staple, cartridge base plate, staple pusher, protective cover, and cutting blade.

Endoscopic Linear Cutter Reloads

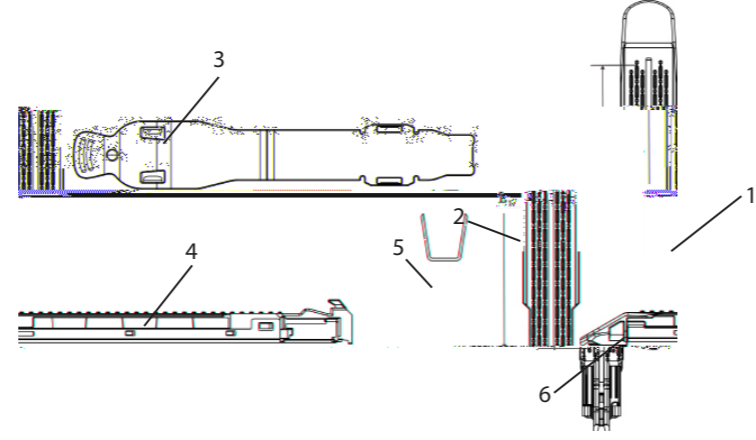

1. Staple cartridge shell 2. Staples 3. Protective cover 4. Staple cartridge baseplate
5. Cutter 6. Pusher

Figure 1 Endoscopic Linear Cutter Reloads

Warning

- The cartridge can only be used in conjunction with the stapler.
- Before use, if rust is found on the product, its use should be strictly prohibited.
- Visually inspect the staple holder for deformation before firing. If deformation is observed, do not use it.
- The stapler cartridge is a single-use, sterile product.
- This product is intended for use in sterile operating rooms within medical facilities.

Note

- After each stapling and suturing, remove the empty staple cartridge from the staple cartridge holder.

Intended purpose

The instruments are intended for transection, resection, and/or creation of anastomoses.

Intended users

Persons having adequate training and familiarity with minimally invasive techniques.

Indications:

The product is intended for transection, resection, and/or creation of anastomoses. The instruments have application in multiple open or minimally invasive general abdominal, gynecologic, thoracic, and pediatric surgical procedures.

Intended patient population

Persons having adequate training and familiarity with minimally invasive techniques.

Description

Product Name: Articulating Endoscopic Linear Cutter
Specifications and Model: See main text for details
Structural Composition: See main text for details
Intended purpose: The instruments are intended for transection, resection, and/or creation of anastomoses.
Registrant/Manufacturer Name: Hangzhou Mindray Medical Technology Co., Ltd.
Registrant/Manufacturer Address: 2 Fengxiang Road, Tonglu Economic Development Zone, Tonglu County, Hangzhou City, Zhejiang Province
Production Address: 2 Fengxiang Road, Tonglu Economic Development Zone, Tonglu County, Hangzhou City, Zhejiang Province
Phone: 0571-58504222
Fax: 0571-58504300
URL: www.mindray.com
Post Code: 311508
Date of Manufacture: See label
Use-by Date: See label
Issue Date of This User Manual: 2024-07



Shanghai International Holding Corp. GmbH (Europe)
Address: Eiffestrasse 80, 20537 Hamburg, Germany
Tel: 0049-40-2513175/2513174

Statement

Thank you for purchasing this product. Before using the product, please read the contents of this user manual carefully to ensure the correct use of the product. Please keep this user manual properly after reading, so that you can refer to it whenever necessary. The intellectual property rights of this product and its instruction manual belong to Hangzhou Mindray Medical Technology Co., Ltd. (hereinafter referred to as Mindray). Mindray has right to final interpretation of this instruction manual. No individual or organization shall copy, modify or translate this instruction manual without the written permission of Mindray. This manual describes the use, function and operation of the product in detail. Before using this product, please read and understand the contents of this manual fully to ensure the correct use of this product and the safety of patients and operators. The user manual is only for product usage instructions, and should not be considered as a reference for surgical techniques. Mindray shall be responsible for the safety, reliability and performance of the product provided that the following conditions are met:

- This product is used in accordance with the Instruction Manual.
- Product damage is caused by non-human factors (human factors refer to accidental drops, deliberate damage, etc.).

If you really need to return the product to Mindray, please contact Mindray's after-sales service department and provide the product model, serial number, and a brief explanation of the reason for the return. The product's "triple guarantee" and the after-sales service are defined by the service contract between the distributor and the manufacturer.

After-sales service provider: Hangzhou Mindray Medical Technology Co., Ltd.
 After-sales provider's address: 2 Fengxiang Road, Tonglu Economic Development Zone, Tonglu County, Hangzhou City, Zhejiang Province
 After-sales provider's telephone: 0571-58504222

To the Customer: Important Information

Safety Signs and Definitions

The safety information contained in this manual helps users identify potential hazards and avoid danger. This manual uses three signs to highlight potential hazards: Warning, Caution, and Note. This manual provides safety information regarding instrument use. Please read and understand all instructions completely before use. Failure to comply with warnings, cautions, and notes related to this instrument, may result in personal injury, instrument malfunction, and void warranty.

Symbol	Description
	In terms of operation or maintenance procedures, failure to strictly adhere to relevant requirements may result in injury or death.
	In terms of operation or maintenance procedures, failure to strictly adhere to relevant requirements may result in equipment damage or destruction.
	Operational tips or maintenance advice; failure to follow these may lead to errors.

Symbol Description

The following table contains all symbols used on this instrument and labels, along with their meanings:

Table 1 Symbol Description

	Follow the instructions for use		Warning
	Unique instrument identifier		Do not re-use
	Temperature limit		Atmospheric pressure limit
	Humidity limit		Refer to the instructions for use
	Single-layer sterile barrier system		Single-layer sterile barrier system, with protective packaging inside
	Manufacturer		Date of Manufacture:
	Use-by Date:		This side up
	Avoid sun exposure		Protect from rain
	Fragile, handle with care		Stacking weight limit 50 kg
	Sterilized using ethylene oxide		Do not resterilize
	Lot Code		For use under medical supervision
	Do not use if packaging is damaged		High-density polyethylene
	Compliant with EU Directive 2012/19/EU on Waste Electrical and Electronic Equipment		Packaging Recycling Label