**DICOM CONFORMANCE
STATEMENT
FOR
M7 DIAGNOSTIC ULTRASOUND
SYSTEM**

Version V7.0 2017-03-16

© mindray 2017
All rights reserved

SHENZHEN MINDRAY BIO-MEDICAL ELECTRONICS CO., LTD.
Mindray Building, Keji 12th Road South, High-tech Industrial Park, Nanshan,
Shenzhen 518057, P.R. China



1 Conformance Statement Overview

This document describes the conformance to the ACR-NEMA DICOM 3.0 Standard by the ultrasound system of M7 Series. We specify ultrasound system generally refer to the products above in this document. The ultrasound system implements the necessary DICOM services to download worklists from an information system, save acquired Ultrasound (US) images and associated Structured Reports to a network storage device and/or removable media, print to a networked hardcopy device, query and retrieve the US images from a networked storage system, and inform the information system about the works actually done. Table 1 provides an overview of the supported network services, Table 2 lists the supported Media Storage Application Profiles, and Table 3 lists the supported Structured Report Templates.

**Table 1
NETWORK SERVICES**

SOP Classes	User of Service (SCU)	Provider of Service (SCP)
Transfer (Storage)		
Verification	Yes	Yes
Ultrasound Image Storage	Yes	Yes
Ultrasound Multi-frame Image Storage	Yes	Yes
Secondary Capture Image Storage	Yes	Yes
Query/Retrieve		
Study Root Query/Retrieve Information Model – FIND	Yes	No
Study Root Query/Retrieve Information Model – MOVE	Yes	No
Workflow Management		
Modality Worklist Information Model – Find	Yes	No
Modality Performed Procedure Step	Yes	No
Storage Commitment Push Model	Yes	No
Print Management		
Basic Color Print Management	Yes	No
Basic Grayscale Print Management	Yes	No



M7 Series Diagnostic Ultrasound System

SOP Classes	User of Service (SCU)	Provider of Service (SCP)
Notes, Reports, Measurements, Transfer		
Comprehensive SR Storage	Yes	Yes

**Table 2
MEDIA SERVICES**

Media Storage Application Profile	Write Files (FSC / FSU)	Read Files (FSR)
Compact Disk - Recordable		
STD-US-SC-SF&MF-CDR	Yes / Yes ¹	Yes
DVD		
STD-US-SC-SF&MF-DVD STD-US-SC-SF&MF-DVD-RAM	Yes / Yes ¹	Yes
USB Devices		
STD-GEN-USB-JPEG for Ultrasound images, compressed and uncompressed and Structured Reports	Yes / Yes ¹	Yes ²

**Table 3
STRUCTURED REPORTS**

Concept Name

2 Table of Contents

1	Conformance Statement Overview.....	III
2	Table of Contents.....	V
3	Introduction.....	1
3.1	Audience.....	1
3.2	Remarks.....	1
3.3	Terms and Definitions.....	1
3.4	Acronyms, Abbreviations, and Symbols.....	4
3.5	References.....	5
4	Networking.....	6
4.1	Implementation Model.....	6
4.1.1	Application Data Flow.....	6
4.1.2	Functional Definitions of AE's.....	7
4.1.3	Sequence of Real World Activities.....	11
4.2	AE Specifications.....	12
4.2.1	Modality AE.....	12
4.3	Network Interface.....	59
4.3.1	Supported Communications Stacks.....	59
4.3.2	TCP/IP Stack.....	59
4.3.3	Physical Network Interface.....	59
4.3.4	Additional Protocols.....	59
4.4	Configuration.....	60
4.4.1	AE Title/Presentation Address Mapping.....	60
4.4.2	Configurable Parameters.....	60
5	Media Storage.....	65
5.1	Implementation Model.....	65
5.1.1	Application Data Flow.....	65
5.1.2	Functional Definition of AE's.....	65
5.1.3	Sequencing of Real-World Activities.....	65
5.1.4	File Meta Information Options.....	66
5.2	AE Specifications.....	66
5.2.1	Media Application Entity Specification.....	66
5.3	Media Storage Application Profile.....	68
5.3.1	DICOMDIR Attributes.....	68
5.4	Augmented and Private Application Profiles.....	70
5.5	Media Configuration.....	70
6	SUPPORT OF CHARACTER SETS.....	71
7	SECURITY.....	72
7.1	Security Profiles.....	72
7.2	Association level security.....	72
7.3	Application level security.....	72
8	ANNEXES.....	73
8.1	IOD contents.....	73
8.1.1	Created SOP Instances.....	73

8.1.2	Usage of attributes from received IOD's	73
8.1.3	Attribute Mapping.....	73
8.1.4	Coerced/Modified fields	73
8.2	Data Dictionary of private attributes	73
8.3	Coded terminology and templates.....	73
8.4	Grayscale Image Consistency.....	73
8.5	Standard extended/specialized/private sop Classes.....	74
8.6	Private Transfer Syntaxes	74
A.	Appendix : OB – GYN structured reporting template.....	75
A.1.	TID (300) Measurement	75
A.2.	TID 1008 Subject Context, Fetus	76
A.3.	TID (5000) OB-GYN Ultrasound Procedure Report.....	76
A.4.	TID (SELFTMP-1) Fetal Cardiac Measurement Group.....	78
A.5.	TID (1001) OBSERVATION CONTEXT	78
A.6.	TID (5001) OB-GYN Patient Characteristics.....	80
A.7.	TID (5002) OB-GYN Procedure Summary.....	80
A.8.	TID (5003) OB-GYN Fetus Summary.....	82
A.9.	TID (FINDING_1) Fetal Description	83
A.10.	TID (FINDING_2) Fetus Limbs	84
A.11.	TID (FINDING_3) Fetal Cardiology.....	85
A.12.	TID (FINDING_4) Fetal Brain	85
A.13.	TID (FINDING_5) Spine.....	86
A.14.	TID (FINDING_6) Fetal Environment.....	86
A.15.	TID (FINDING_7) Maternal Description.....	87
A.16.	TID (5004)Fetal Biometry Ratio Section.....	87
A.17.	TID (5005) Fetal Biometry Section	88
A.18.	TID (5006) Fetal Long Bones Section	89
A.19.	TID (5007) Fetal Cranium Section	89
A.20.	TID (5008) Fetal Biometry Group	90
A.21.	TID (5009) Fetal Biophysical Profile Section	90
A.22.	TID (5010) Amniotic Sac Section.....	92
A.23.	TID (5011) Early Gestation Section	92
A.24.	TID (5012) Ovaries Section	93
A.25.	TID (5013) Follicles Section.....	94
A.26.	TID (5014) Follicle Measurement Group	95
A.27.	TID (5015) Pelvis And Uterus Section	96
A.28.	TID (5025) OB-GYN Fetus Vascular Ultrasound Measurement Group	97
A.29.	TID (5026) OB-GYN Pelvic Vascular Ultrasound Measurement Group.....	98
A.30.	CID (228) Equation or Table	98
A.31.	CID (244) Laterality.....	98
A.32.	CID (3627) Measurement Type	98
A.33.	CID (12005) Fetal Biometry Measurements	99
A.34.	CID (12006) Fetal Long Bones Measurements	100
A.35.	CID (12007) Fetal Cranium.....	100
A.36.	CID (12009) Early Gestation Biometry Measurements	100
A.37.	CID (12013) Gestational Age Equations and Tables	101

B.32.	CID (12230) Gradient Methods.....	134
B.33.	CID (12231) Volume Flow Methods.....	135
B.34.	CID (12232) Myocardium Mass Methods.....	135
B.35.	CID (12233) Cardiac Phase.....	135
B.36.	CID (12234) Respiration Phase.....	135
B.37.	CID (12239) Cardiac Output Properties	135
B.38.	CID (12240) Left Ventricle Area	136
B.39.	CID (90000) Pericardial disease.....	136
B.40.	Mapping between Modality measurements and DICOM Concepts.	136
B.40.1.	Left Ventricle Measurements	136
B.40.2.	Right Ventricle Measurements.....	153
B.40.3.	Left Atrium Measurements	154
B.40.4.	Right Atrium Measurements.....	155
B.40.5.	Aortic Valve Measurements	156
B.40.6.	Mitral Valve Measurements.....	158
B.40.7.	Pulmonic Valve Measurements.....	163
B.40.8.	Tricuspid Valve Measurements.....	165
B.40.9.	Aorta Measurements.....	167
B.40.10.	Pulmonary Artery Measurements	168
B.40.11.	Vena Cava Measurements.....	169
B.40.12.	Pulmonary Venous Structure Measurements	169
B.40.13.	Cardiac Shunt Study Measurements	170
B.40.14.	Congenital Anomaly of Cardiovascular System Measurements.....	170
B.40.15.	Pericardial Disease Measurements.....	171
B.40.16.	Heart Rate Measurements.....	171
C.	Appendix : Vascular structured reporting template.....	172
C.1.	TID (5100) Vascular Ultrasound Report.....	172
C.2.	TID (1001) Observation Context	178
C.3.	TID (5101) Vascular Patient Characteristics	179
C.4.	TID (5102) Vascular Procedure Summary Section	180
C.5.	TID (5103) Vascular Ultrasound Section.....	182
C.6.	TID (5104) Vascular Ultrasound Measurement Group.....	182
C.7.	CID (12104) Extracranial Arteries.....	183
C.8.	CID (12105) Intracranial Cerebral Vessels.....	183
C.9.	CID (12106) Intracranial Cerebral Vessels (unilateral)	184
C.10.		

C.19.2.	Extracranial Arteries.....	187
C.19.3.	Intracranial Cerebral Vessels.....	188
C.19.4.	Intracranial Cerebral Vessels (unilateral)	188
C.19.5.	Upper Extremity Arteries.....	188
C.19.6.	Upper Extremity Arteries(unilateral).....	188
C.19.7.	Upper Extremity Veins	188
C.19.8.	Lower Extremity Arteries.....	189
C.19.9.	Lower Extremity Veins	189
C.19.10.	Abdominal Arteries (unilateral)	190
C.19.11.	Abdominal Veins (unilateral)	190
C.19.12.	Renal Vessels	190

3 Introduction

3.1 Audience

This document is intended for potential customers, system integrators of medical equipment, marketing staff interested in system functionality and software designers implementing DICOM interfaces. It is assumed that the readers of this document are familiar with the DICOM Standard and with the terminology and concept which are used in the Standard. If readers are unfamiliar with DICOM terminology they should read the DICOM Standard, prior to reading this DICOM Conformance Statement document.

3.2 Remarks

The scope of this DICOM Conformance Statement is to facilitate integration between Mindray Products and other DICOM products. The Conformance Statement should be read and understood in conjunction with the DICOM Standard. DICOM by itself does not guarantee interoperability. The Conformance Statement does, however, facilitate a first-level comparison for interoperability between different applications supporting compatible DICOM functionality.

This Conformance Statement is not supposed to replace validation with other DICOM equipment to ensure proper exchange of intended information. In fact, the user should be aware of the following important issues:

- The comparison of different Conformance Statements is the first step towards assessing interconnectivity and interoperability between Mindray medical equipment and other DICOM conformant equipments.
- Test procedures should be defined and executed to validate the required level of interoperability with specific compatible DICOM equipment, as established by the healthcare facility.
- The DICOM standard will evolve to meet the user's growing requirements. Mindray is actively involved in the development of the DICOM standard. Therefore,

Application Context – the specification of the type of communication used between *Application Entities*. Example: DICOM network protocol.

Application Entity (AE) – an end point of a DICOM information exchange, including the DICOM network or media interface software; i.e., the software that sends or receives DICOM information objects or messages. A single device may have multiple Application Entities.

Application Entity Title – the externally known name of an *Application Entity*, used to identify a DICOM application to other DICOM applications on the network. The Called AE Title defines the intended receiver of an Association. Nevertheless, the Calling AE Title defines the requestor of an Association.

Application Profile - A Media Storage Application Profile defines a selection of choices at the various layers of the DICOM Media Storage Model which are applicable to a specific need or context in which the media interchange is intended to be performed.

Association – a network communication channel set up between *Application Entities*.

Association Establishment - an Association Establishment is the first phase of communication between two DICOM Application Entities. The AEs use the Association Establishment to negotiate how data will be encoded and the type of data to be exchanged.

Attribute – a unit of information in an object definition; a data element identified by a *tag*. The information may be a complex data structure (Sequence), itself composed of lower level data elements. Examples: Patient ID (0010,0020), Accession Number (0008,0050), Photometric Interpretation (0028,0004), Procedure Code Sequence (0008,1032).

DICOM File Format - the DICOM File Format provides a means to encapsulate in a File the Data Set representing a SOP Instance related to a DICOM Information Object.

DICOM Message Service Element (DIMSE) – a DIMSE defines the services and protocols utilized by an Application Entity to exchange messages.

File - a File is an ordered string of zero or more bytes, where the first byte is at the beginning of the file and the last byte is at the end of the File. Files are identified by an unique File ID and may be written, read, or deleted.

Information Object Definition (IOD) - the specified set of *Attributes* that comprise a type of data object; does not represent a specific instance of the data object, but rather a class of similar data objects that have the same properties. The *Attributes* may be specified as Mandatory (Type 1), Required but possibly unknown (Type 2), or Optional (Type 3), and there may be conditions associated with the use of an Attribute (Types 1C and 2C). Examples: Print Job IOD.

Joint Photographic Experts Group (JPEG) – a set of standardized image compression techniques, available for use by DICOM applications.

Module – a set of *Attributes* within an *Information Object Definition* that are logically

related to each other. Example: Patient Module includes Patient Name, Patient ID, Patient Birth Date, and Patient Sex.

Negotiation – first phase of *Association* establishment that allows *Application Entities* to agree on the types of data to be exchanged and how that data will be encoded.

Physical Media - a piece of material with recording capabilities for streams of bits. Characteristics of a Physical Media include form factor, mechanical characteristics, recording properties and rules for recording and organizing bit streams in accessible structures.

Presentation Context – the set of DICOM network services used over an *Association*, as negotiated between *Application Entities*; includes *Abstract Syntaxes* and *Transfer Syntaxes*.

Protocol Data Unit (PDU) – a packet (piece) of a DICOM message sent across the network. Devices must specify the maximum size packet they can receive for DICOM messages.

Security Profile – a set of mechanisms, such as encryption, user authentication, or digital signatures, used by an *Application Entity* to ensure confidentiality, integrity, and/or availability of exchanged DICOM data

Service Class Provider (SCP) – role of an *Application Entity* that provides a DICOM network service; typically, a server that performs operations requested by another *Application Entity* (*Service Class User*). Examples: Picture Archiving and Communication System (image storage SCP, and image query/retrieve SCP), Radiology Information System (modality worklist SCP).

Service Class User (SCU) – role of an *Application Entity* that uses a DICOM network service; typically, a client. Examples: imaging modality (image storage SCU, and modality worklist SCU), imaging workstation (image query/retrieve SCU)

Service/Object Pair (SOP) Class – the specification of the network or media transfer (service) of a particular type of data (object); the fundamental unit of DICOM interoperability specification. Examples: Ultrasound Image Storage Service, Basic Grayscale Print Management.

Service/Object Pair (SOP) Instance – an information object; a specific occurrence of information exchanged in a *SOP Class*. Examples: a specific x-ray image.

Tag – a 32-bit identifier for a data element, represented as a pair of four digit hexadecimal numbers, the “group” and the “element”. If the “group” number is odd, the tag is for a private (manufacturer-specific) data element. Examples: (0010,0020) [Patient ID], (07FE,0010) [Pixel Data], (0019,0210) [private data element]

Transfer Syntax – the encoding used for exchange of DICOM information objects and messages. Examples: *JPEG* compressed (images), little endian explicit value representation.

Unique Identifier (UID) – a globally unique “dotted decimal” string that identifies a specific object or a class of objects; an ISO-8824 Object Identifier. Examples: Study Instance UID, SOP Class UID, SOP Instance UID.

Value Representation (VR) – the format type of an individual DICOM data element, such as text, an integer, a person’s name, or a code. DICOM information objects can be transmitted with either explicit identification of the type of each data element (Explicit VR), or without explicit identification (Implicit VR); with Implicit VR, the receiving application must use a DICOM data dictionary to look up the format of each data element.

3.4 Acronyms, Abbreviations, and Symbols

The following acronyms and abbreviations are used in this document.

ACR	American College of Radiology
AE	Application Entity
CDR	Compact Disk Recordable
DICOM	Digital Imaging and Communications in Medicine
DIMSE	DICOM Message Service Element
DIMSE-C	DICOM Message Service Element-Composite
FSC	File-Set Creator
FSR	File-Set Reader
FSU	File-Set Updater
HIS	Hospital Information System
IHE	Integrating the Healthcare Enterprise
IOD	Information Object Definition
ISO	International Standard Organization
JPEG	Joint Photographic Experts Group
MODALITY	Ultrasound System
MPPS	Modality Performed Procedure Step
MWL	Modality Worklist
NEMA	National Electrical Manufacturers Association
O	Optional (Key Attribute)
PACS	Picture Archiving and Communication System
PDU	Protocol Data Unit
R	Required (Key Attribute)
RIS	Radiology Information System
SCP	Service Class Provider
SCU	Service Class User
SOP	Service Object Pair
SR	Structured Reporting
TCP/IP	Transmission Control Protocol/Internet Protocol

U	Unique (Key Attribute)
UL	Upper Layer
VR	Value Representation
US	Ultrasound
UID	Unique Identifier

3.5 References

DICOM Quick Guide & FAQ, Mindray Co. Ltd

Digital Imaging and Communications in Medicine (DICOM), NEMA PS 3, available free at <http://medical.nema.org/>

IHE Technical Framework, available free at www.ihe-europe.net

4 Networking

4.1 Implementation Model

4.1.1 Application Data Flow

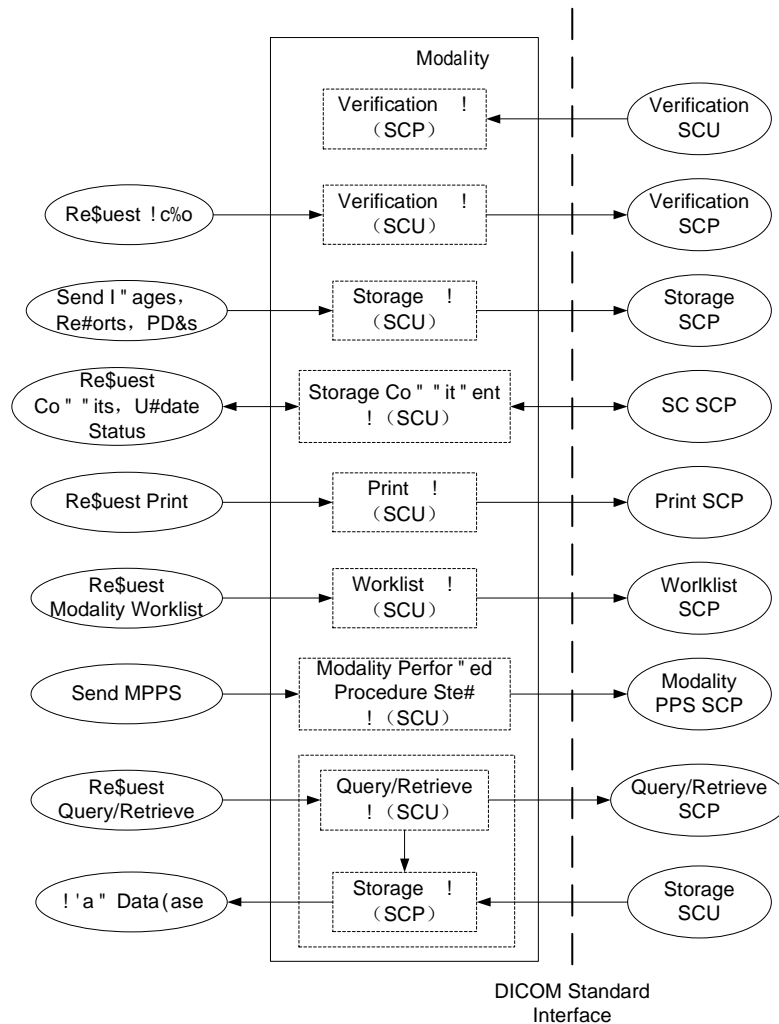

Figure 1

Implementation Model

Note: Storage AE (SCP) only be used in Query/Retrieve

This application entity provides a user interface, internal database and network listener that spawns additional threads as necessary to handle incoming connections.

Conceptually the network services may be modeled as the following AE's, however, in fact all the AE's share a single (configurable) AE Title:

Verification AE (as SCU and SCP)

Storage AE (as SCU and SCP)
Storage Commitment AE (SCU)
Print AE (as SCU)
Worklist AE (as SCU)
MPPS AE (as SCU)
Query/Retrieve AE (as SCU)

4.1.2 Functional Definitions of AE's

4.1.2.1 Verification AE

The ultrasound system supports the Verification service as a SCU and SCP.

As a SCU, verification is activated when the verify button is selected on the dicom service configuration page where the verification results will also be showed to the user.

As a SCP, verification AE waits in the background for connections, will accept associations with Presentation Contexts for SOP Class of the Verification Service Class, and will respond successfully to echo requests.

4.1.2.2 Storage AE

As a SCU, the Storage AE originates associations for the transfer of DICOM Ultrasound

DICOM composite information objects on remote DICOM device after sending DICOM Storage Service to the device.

The Storage Commitment service will be executed automatically in the circumstance as below:

The Storage Commitment Service is set to associate with the Storage Service in DICOM storage service preset dialog and the associated Storage Service is executed. Exam is the unit to send.

The status of the exam is "End". It would not be executed when an "Active", "Paused" or "Cancelled" exam is selected.

4.1.2.4 Print AE

As a SCU, the Print AE originates associations for the print of DICOM Ultrasound single frame images and secondary capture images to remote AE (selected from a pre-configured list).

The system is capable of grayscale (B/W) and color print supporting with automatic and manual print functions.

The operations for automatic print service are described below:

Operation 1

Step 1: Enable "Send or printing after End Exam" in the user preset.

Step 2: End Exam, the single frame images and secondary capture images of ended exam would automatically send to the default print service SCPs which are set to be default in the DICOM service preset dialog.

Notes: This operation associates with the "Display Format" of the DICOM print preset, the DICOM print will be not active until one page is filled with the images or the exam end. For example, if the "Display Format" has been set to "STANDARD\2,3", the DICOM print will be not active until the shortcut key has been pressed 6 times. However, when the exam end, the DICOM print will be active even if one page is not filled.

Operation 2

Step 1: Open the system preset dialog and switch to the "key config" tab page.

Step 2: Set the shortcut key which means sending image to the default DICOM print SCPs.

Step 3: During the examining, the user can press the print key to send image to default DICOM print service SCPs.

The operations for manual print service are described below:

Operation 1

Step 1: Select the images from thumbnail menu in main UI.



Step 2: Press “Send to” button and select DICOM print service SCPs.

Step 3: Send the image to the DICOM print service SCPs.

Operation 2

Step 1: Select exams in the iStation Dialog.

Step 2: Press “Send Exam” and select DICOM print service SCPs.

Step 3: Send the single frame images and secondary capture images of the selected exams to the DICOM print service SCPs.

Operation 3

Step 1: Select thumbnail in the iStation Dialog.

Step 2: Press “Send to” button and select DICOM print service SCPs.

Step 3: Send the image to the DICOM print service SCPs.

Operation 4

Step 1: Open the review dialog and select the images.

Step 2: Press the “Send To” button to choose the print SCPs.

Step 3: Send the image to the DICOM print service SCPs.

4.1.2.5 Worklist AE

The Worklist AE is activated through the Worklist UI when the user selects a remote AE to query (from a pre-configured list). The system supports automatic and manual query depending on its configuration on Preset UI. The system supports fuzzy query using “?” and “*”.

If set one and only one remote AE to be default status. The system can initiate a query with default rules when show the Worklist UI. The Worklist Server is the default server. The Modality Type is US, the Exam Date is today, and the Scheduled Station AE Title is blank.

Alternatively if the default status is no, the user can specify query rules on Worklist UI. Such as Patient ID, Patient Name, Accession Number, Requested Procedure ID, Worklist Server, Exam Date, Modality Type and Scheduled Station AE Title.

If no matches are found, a dialogue will be presented to the user to indicate so. The possible reasons for this failure are listed to help trouble shooting.

If more than one matching patients found, user can discover lists number on the UI. The user can also change query rules for another query, or for further filter in local database to locate the patients quickly. And the lists can be sorted in ascending or descending order.

4.1.2.6 MPPS AE

4.2 AE Specifications

4.2.1 Modality AE

4.2.1.1 SOP Classes

The ultrasound system provides Standard Conformance to the following SOP Class:

Table 4
SOP Class for Modality AE

SOP Class Name	SOP Class UID	SCU	SCP
Verification SOP Class	1.2.840.10008.1.1	Yes	Yes
US Image Storage	1.2.840.10008.5.1.4.1.1.6.1	Yes	Yes ¹
US Multiframe Image Storage	1.2.840.10008.5.1.4.1.1.3.1	Yes	Yes ¹
Secondary Capture Image Storage	1.2.840.10008.5.1.4.1.1.7	Yes	Yes ¹
Comprehensive Structured Report Storage	1.2.840.10008.5.1.4.1.1.88.33	Yes	Yes ¹
Storage Commitment Push Model	1.2.840.10008.1.20.1	Yes	No
Basic Grayscale Print Management Meta	1.2.840.10008.5.1.1.9	Yes	No
Basic Color Print Management Meta SOP Class	1.2.840.10008.5.1.1.18	Yes	No
Basic Film Session SOP Class	1.2.840.10008.5.1.1.1	Yes	No
Basic Film Box SOP Class	1.2.840.10008.5.1.1.2	Yes	No
Basic Grayscale Image Box SOP Class	1.2.840.10008.5.1.1.4	Yes	No
Printer SOP Class	1.2.840.10008.5.1.1.16	Yes	No
Print Job SOP Class	1.2.840.10008.5.1.1.14	Yes	No
Modality Worklist Information Model - Find	1.2.840.10008.5.1.4.31	Yes	No
Modality Performed Procedure Step SOP Class	1.2.840.10008.3.1.2.3.3	Yes	No
Study Root Query/Retrieve Information Model - Find	1.2.840.10008.5.1.4.1.2.2.1	Yes	No
Study Root Query/Retrieve Information Model - Move	1.2.840.10008.5.1.4.1.2.2.2	Yes	No

Note: 1 Yes only used in Query/Retrieve, otherwise No.

4.2.1.2 Association Establishment Policies

4.2.1.2.1 General

The DICOM standard application context name for DICOM 3.0 is always proposed:

Table 5
DICOM Application Context for Modality AE



M7 Series Diagnostic Ultrasound System

Application Context Name	1.2.840.10008.3.1.1.1
--------------------------	-----------------------

The PDU size is configurable with a minimum size of 16,384 and a maximum size of 65,536. The default PDU size is 32,768.

4.2.1.2.2 Number of Associations

The system initiates one Association at a time for each destination to which a transfer request is being processed in the active job queue list. Since Storage and Print tasks are executed within a same thread, when they are selected simultaneously, only one job will be active at a time, the other(s) remain pending until the active job is successful or failed.

Table 6
Number of Associations as an Association Initiator

Maximum number of simultaneous associations	1
---	---

Table 7
Number of Associations as an Association Acceptor

Maximum number of simultaneous associations	1
---	---

4.2.1.2.3 Asynchronous Nature

The ultrasound system will only allow a single outstanding operation on an association.

4.2.1.2.4 Implementation Identifying Information

Table 8
DICOM Implementation Class and Version for Modality AE

Implementation Class UID	1.2.156.112536.1.2118.0.1.0.1
Implementation Version Name	MINDRAY_V1.0

4.2.1.3 Association Initiation Policy

4.2.1.3.1 Activity – Request Echo

4.2.1.3.1.1 Description and Sequencing of Activities

The user can verify the existence of a DICOM server on the hospitals network, through a button in the 'DICOM Service' screen. When the user presses this button, the ultrasound system will initiate the association.

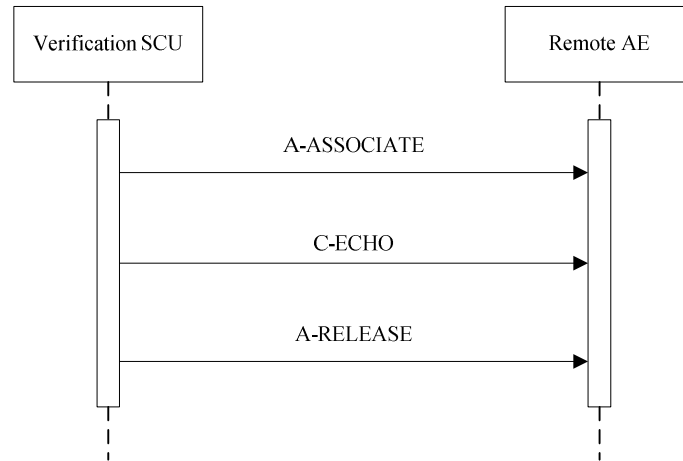

Figure 2
Sequencing of Activity – Send Echo Request

4.2.1.3.1.2 Proposed Presentation Contexts

The Verification AE (as SCU) supports the following Presentation Contexts for Verification.

Table 9
Presentation Contexts for Verification

PROPOSED PRESENTATION CONTEXTS					
Abstract Syntax		Transfer Syntax		Role	Ext. Neg.
Name	UID	Name	UID		
Verification	1.2.840.10008.1.1	Implicit VR Little Endian	1.2.840.10008.1.2	SCU	None
		Explicit VR Little Endian	1.2.840.10008.1.2.1	SCU	None
		Explicit VR Big Endian	1.2.840.10008.1.2.2	SCU	None

4.2.1.3.1.3 SOP Specific Conformance

It summarizes the behavior of Ultrasound System when receiving status codes in a C-ECHO response.

Table 10
Verification C-Echo Response Status Handling Behavior

Service Status	Further Meaning	Error Code	Behavior (as SCU)
Success	Success	0000	Device Status is set to: Verify Successful
Refused	Out of Resources	A7XX	Device Status is set to: Verify Failed
Failed	Unable to process	CXXX	Device Status is set to: Verify Failed
*	*	Any other status code	Device Status is set to: Verify Failed



4.2.1.3.2 Activity – Store images, SRs

4.2.1.3.2.1 Description and Sequencing of Activities

For each exam, image selected from the user interface to be transferred, an attempt will be made to transfer it to the selected remote AE. When the storage fails, not only the failed task will automatically retry specific times if configured on Preset UI, but also user can restart the failed task by pressing “Retry” Button on the ultrasound task management dialog.

Structured Reports will contain only a part of common used measurements and calculations created by ultrasound system. And User

4.2.1.3.2 Proposed Presentation Contexts

If Storage AE is offered a choice of Transfer Syntaxes in the accepted Presentation Contexts, it will apply the first encountered to use for the C-STORE operation. As to Compress Transfer Syntaxes, it will apply the user configured one.

**Table 11
Proposed Presentation Contexts for Storage**

PROPOSED PRESENTATION CONTEXTS					
Abstract Syntax		Transfer Syntax		Role	Ext. Neg.
Name	UID	Name	UID		
US Image	1.2.840.100				
Storage	08.5.1.4.1.1				
	.6.1				



M7 Series Diagnostic Ultrasound System

		Value 1)			
		RLE Lossless	1.2.840.10008.1.2.5	SCU	None
		JPEG 2000 Image Compression (Lossless Only)	1.2.840.10008.1.2.4. 90	SCU	None
		JPEG 2000 Image Compression	1.2.840.10008.1.2.4. 91	SCU	None



M7 Series Diagnostic Ultrasound System

		Compression (Lossless Only)	90		
		JPEG 2000 Image Compression	1.2.840.10008.1.2.4.91	SCU	None

4.2.1.3.2.3 SOP Specific Conformance

Storage AE provides Standard Conformance to the Storage Service Class.

Storage AE will behave as described in the Table below in response to the status returned in the C-STORE response command message.

Table 12
Storage C-STORE Response Status Handling Behavior

Service Status	Further Meaning	Error Code	Behavior
Success	Success	0000	Image transmission is successful, The status code is logged and the task success is reported to the user via task management.
Refused	Out of Resources	A7xx	The association is aborted using A-ABORT and the send task is marked as failed. The reason is logged and, If user selects the failed task, the reasons for this failure will be showed via task management.
Error	Data Set does not match SOP Class	A9xx	The association is aborted using A-ABORT and the send task is marked as failed. The reason is logged and, If user selects the failed task, the reasons for this failure will be showed via task management.
Error	Cannot Understand	Cxxx	The association is aborted using A-ABORT and the send job is marked as failed. The reason is logged and, If user selects the failed task, the reasons for this failure will be showed via task management.
Failure	Any other failure	xxxx	The association is aborted using A-ABORT and the send job is marked as failed. The reason is logged and, If user selects the failed task, the reasons for this failure will be showed via task management.
Warning	Coercion of Data Elements	B000	Image transmission is considered successful but the status meaning is logged.
	Data Set does not match SOP Class	B007	Image transmission is considered successful but the status meaning is logged.
	Elements Discarded	B006	Image transmission is considered successful but the status meaning is logged.
	Any other status	xxxx	The Association is aborted using A-ABORT and the



M7 Series Diagnostic Ultrasound System

	code.		send job is marked as failed. The status code is logged and the job failure is reported to the user via task management.
--	-------	--	--

The behavior during communication failure is summarized in the Table below:

Table 13

Storage Communication Failure Behavior

Exception	Behavior
Timeout	The Association is aborted using A-ABORT and the send job is marked as failed. The reason is logged and the job failure is reported to the user via task management.
Association aborted by the SCP or network layers	The send job is marked as failed. The reason is logged and the job failure is reported to the user via task management.

The following table provides the list of attributes requested in the Storage.

Table 14

Storage IOD Attribute

ATTRIBUTE	VR	TYPE	ATTRIBUTE NAME	VALUE(S) AND COMMENTS
Module: Patient Module (M)				
(0010,0010)	PN	2	Patient's Name	MWL/USER
(0010,0020)	LO	2	Patient ID	MWL/USER
(0010,0030)	DA	2	Patient's Birth Date	MWL/USER, default is set to zero length
(0010,0040)	CS	2	Patient's Sex	MWL/USER, default is set to zero length
(0010,1000)	LO	3	Other Patient IDs	MWL
(0010,2160)	SH	3	Ethnic Group	MWL
(0010,4000)	LT	3	Patient Comments	MWL/USER
Module: General Study Module (M)				
(0008,0020)	DA	2	Study Date	AUTO
(0008,0030)	TM	2	Study Time	AUTO
(0008,0050)	SH	2	Accession Number	MWL/USER, default is set to zero length
(0008,0090)	PN	2	Referring Physician's Name	MWL/USER, default is set to zero length
(0008,1030)	LO	3	Study Description	MWL/USER, default is set to zero length
(0008,1032)	SQ	3	Procedure Code Sequence	MWL
(0020,000D)	UI	1	Study Instance UID	MWL/AUTO
(0020,0010)	SH	2	Study ID	AUTO



M7 Series Diagnostic Ultrasound System

Module: Patient Study Module (U)				
(0008,1080)	LO	3	Admitting Diagnoses Description	MWL
(0010,1010)	AS	3	Patient's Age	MWL/USER, default is set to zero length If the user set Patient Birth Date, it will be calculated automatically.
(0010,1020)	DS	3	Patient's Size	MWL/USER, default is set to zero length
(0010,1030)	DS	3	Patient's Weight	MWL/USER, default is set to zero length
(0010,21B0)	LT	3	Additional Patient History	MWL
Module: General Series Module (M)				
(0008,0021)	DA	3	Series Date	AUTO
(0008,0031)	TM	3	Series Time	AUTO
(0008,0060)	CS	1	Modality	"US"
(0008,103E)	LO	3	Series Description	MWL
(0008,1050)	PN	3	Performing	



M7 Series Diagnostic Ultrasound System

(0008,0080)	LO	3	Institution Name	CONFIG
(0008,1010)	SH	3	Station Name	CONFIG
(0008,1040)	LO	3	Institutional Department Name	CONFIG
(0008,1090)	LO	3	Manufacturer's Model Name	M7
(0018,1000)	LO	3	Device Serial Number	The Ethernet card Mac Address
(0018,1020)	LO	3	Software Version(s)	AUTO
Module: General Image Module (M)				
(0008,0023)	DA	2C	Content Date	AUTO
(0008,0033)	TM	2C	Content Time	AUTO
(0008,2111)	ST	3	Derivation Description	CONFIG, default is set to zero length
(0020,0013)	IS	2	Instance Number	AUTO
(0020,0020)	CS	2C	Patient Orientation	Set to zero length
(0020,4000)	LT	3	Image Comments	Set to zero length
(0028,0301)	CS	3	Burned In Annotation	YES
Module: US Image Module (M)				
(0008,0008)	CS	2	Image Type	ORIGINAL/PRIMARY
(0018,5010)	LO	3	Transducer Data	USER
(0018,5020)	LO	3	Processing Function	USER
(0028,0002)	US	1	Samples per Pixel	1 or 3
(0028,0004)	CS	1	Photometric Interpretation	RGB, for color images; MONOCHROME2, if the image is grayscale; YBR_FULL_422, if the image is sent using JPEG. RGB, if the image is sent using JPEG Lossless. YBR_FULL, if the image is sent using RLE Lossless. YBR_ICT, if the image is sent using JPEG 2000 Image Compression. YBR_RCT, if the image is sent using



M7 Series Diagnostic Ultrasound System

				JPEG 2000 Image Compression (Lossless Only)
(0028,0006)	US	1C	Planar Configuration	1, if the image is sent using RLE Lossless 0, otherwise.
(0028,0009)	AT	1C	Frame Increment Pointer	Frame Time
(0028,0014)	US	3	Ultrasound Color Data Present	0 or 1
(0028,0100)	US	1	Bits Allocated	0x0008
(0028,0101)	US	1	Bits Stored	0x0008
(0028,0102)	US	1	High Bit	0x0007
(0028,0103)	US	1	Pixel Representation	0x0000
(0028,2110)	CS	1C	Lossy Image Compression	Not used if image is uncompressed; support JPEG baseline, JPEG Lossless,RLE Lossless,JPEG 2000 Image Compression,JPEG 2000 Image Compression (Lossless Only) process1 and set it to “01”
Module: Image Pixel Module (M)				
(0028,0010)	US	1	Rows	CONFIG
(0028,0011)	US	1	Columns	CONFIG
(0028,0034)	IS	1c	Pixel Aspect Ratio	Set to zero length
(7FE0,0010)	OW	1	Pixel Data	
Module: SOP Common Module (M)				
(0008,0005)	CS	1C	Specific Character Set	ISO_IR 100
(0008,0012)	DA	3	Instance Creation Date	AUTO
(0008,0013)	TM	3	Instance Creation Time	AUTO
(0008,0016)	UI	1C	SOP Class UID	AUTO
(0008,0018)	UI	1C	SOP Instance UID	AUTO
Module: US Region Calibration Module (U)				
(0018,6011)	SQ	1	Sequence of Ultrasound Regions	
>(0018,6012)	US	1	Region Spatial Format	Set by the system



M7 Series Diagnostic Ultrasound System

>(0018,6014)	US	1	Region Data Type	Set by the system
>(0018,6016)	UL	1	Region Flags	Set by the system
>(0018,6018)	UL	1	Region Location Min X0	Set by the system
>(0018,601A)	UL	1	Region Location Min Y0	Set by the system
>(0018,601C)	UL	1	Region Location Max X1	Set by the system
>(0018,601E)	UL	1	Region Location Max Y1	Set by the system
>(0018,6024)	US	1	Physical Units X Direction	Set by the system
>(0018,6026)	US	1	Physical Units Y Direction	Set by the system
>(0018,602C)	FD	1	Physical Delta X	Set by the system
>(0018,602E)	FD	1	Physical Delta Y	Set by the system
Module: Cine Module (M)				
Used for US Multi-Frame Images Only				
(0008,2142)	IS	3	Start Trim	Set by the system

Module: SC Equipment Module (M)				
Used for Second Capture Images Only				
(0008,0060)	CS	3	Modality	US
(0008,0064)	CS	1	Conversion Type	WSD
(0018,1010)	LO	3	Secondary Capture Device ID	M7
(0018,1016)	LO	3	Secondary Capture Device Manufacturer	MINDRAY
(0018,1018)	LO	3	Secondary Capture Device Manufacturer's Model Name	M7
(0018,1019)	LO	3	Secondary Capture Device Software Version(s)	AUTO
Module: SC Image Module (M)				
Used for Second Capture Images Only				
(0018,1012)	DA	3	Date of Secondary Capture	AUTO
(0018,1014)	TM	3	Time of Secondary Capture	AUTO

Conventions used for the Value(s) and Comments section are:

MWL – the attribute value source is from Modality WORKLIST

USER – the attribute value source is from User's input

AUTO – automatically generated by the MODALITY system

CONFIG - the attribute value source is a configurable parameter

4.2.1.3.3 Activity – Film Images

4.2.1.3.3.1 Description and Sequencing of Activities

A user composes images onto film sheets and requests them to be sent to a specific hardcopy device. The user can select the desired film format and number of copies. Each print-job is forwarded to the job queue and processed individually.

The system is invoked by the user on "Send to" UI if the print remote AE is pre-configured. Status of the print-job is reported through task management UI. If pre-configured on Preset UI, the failed print task will be automatically retried specified times. If no pre-configuration, the user can also retry manually. Only one task will be active at a time for each separate hardcopy device.

A typical sequence of DIMSE messages sent over an association between Print AE and a Printer is illustrated in Figure 4:



1. Print AE opens an association with the Printer.
2. N-GET on the Printer SOP Class is used to obtain current printer status information.
3. N-CREATE on the Film Session SOP Class creates a Film Session.
4. N-CREATE on the Film Box SOP Class creates a Film Box linked to the Film Session. A single Image Box will be created as the result of this operation (Print AE default uses the format STANDARD\1.1, but user can change it on Preset UI).
5. N-SET on the Image Box SOP Class transfers the contents of the film sheet to the printer.
6. N-ACTION on the Film Box SOP Class instructs the printer to print the Film Box.
7. The Printer prints the requested number of film sheets.
8. The Printer asynchronously reports its status via N-EVENT-REPORT notification (Printer SOP Class). The Printer can send this message at any time. Print AE does not require the N-EVENT-REPORT to be sent. Print AE is capable of receiving an N-EVENT-REPORT notification at any time during an association.
9. N-DELETE on the Film Box SOP Class deletes the complete Film box SOP Instance hierarchy.
10. N-DELETE on the Film Session SOP Class deletes the complete Film Session SOP Instance hierarchy.
11. Print AE closes the association with the Printer.

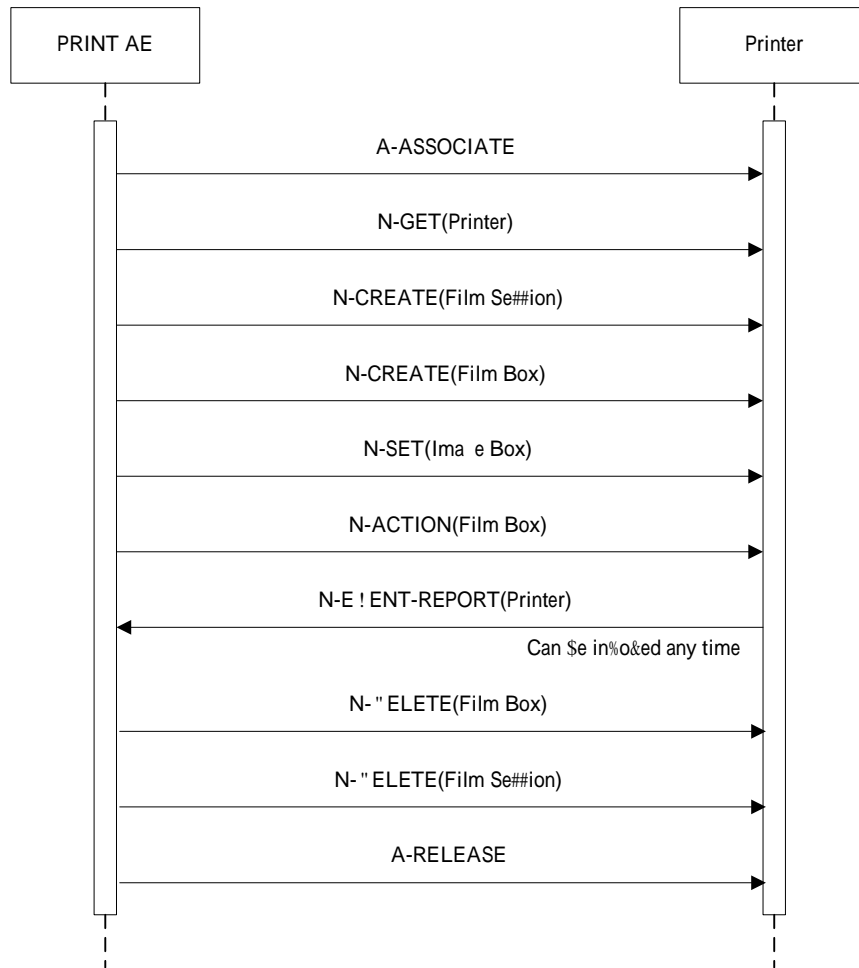

Figure 4
Sequencing of Activity – Film Images

4.2.1.3.3.2 Proposed Presentation Contexts

Print AE is capable of proposing the Presentation Contexts shown in the Table below:

Table 15
Proposed Presentation Contexts for Activity Film Images

Presentation Context Table					
Abstract Syntax		Transfer Syntax		Role	Ext. Neg.
Name	UID	Name List	UID List		



M7 Series Diagnostic Ultrasound System

Basic Grayscale Print Management Meta	1.2.840.10008.5.1.1.9	Implicit VR Little Endian	1.2.840.10008.1.2	SCU	None
		Explicit VR Little Endian	1.2.840.10008.1.2.1	SCU	None
		Explicit VR Big Endian	1.2.840.10008.1.2.2	SCU	None

4.2.1.3.3.3 Common SOP Specific Conformance for all Print SOP Classes

The general behavior of Print AE during communication failure is summarized in the Table below. This behavior is common for all SOP Classes supported by Print AE.

Table 16
Print AE Communication Failure Behavior

Exception	Behavior
Timeout	The association is aborted using A-ABORT and the print-job is marked as failed.
Association aborted by the SCP or network layers	The print-job is marked as failed. The reason is logged and the job failure is reported to the user.

Recommended abbreviations to be used for the tables are:

- VNAP Value Not Always Present (attribute sent zero length if no value is present)
- ANAP Attribute Not Always Present
- ALWAYS Always Present with a value
- EMPTY Attribute is sent without a value

Recommended abbreviations to be used for the source of the data values in the tables are:

- USER the attribute value source is from User input
- AUTO the attribute value is generated automatically
- CONFIG the attribute value source is a configurable parameter
- PRINTER the attribute value is provided by printer

4.2.1.3.3.4 SOP Specific Conformance for the Printer SOP Class

Print AE supports the following DIMSE operations and notifications for the Printer SOP Class:

- N-GET
- N-EVENT-REPORT

Details of the supported attributes and status handling behavior are described in the following subsections.

4.2.1.3.3.4.1 Printer SOP Class Operations (N-GET)



M7 Series Diagnostic Ultrasound System

Print AE uses the Printer SOP Class N-GET operation to obtain information about the current printer status. The attributes excepted via N-GET are listed in the Table below:

Table 17
Printer SOP Class N-GET Request Attribute Identifier List

Attribute Name	Tag
-----------------------	------------



M7 Series Diagnostic Ultrasound System

		application.
*	*	An invalid Event Type ID will cause a status code of 0113H to be returned in a N-EVENT-REPORT response.

Print AE is capable of receiving an N-EVENT-REPORT request at any time during an association. The behavior of Print AE when receiving Event Types within the N-EVENT-REPORT is summarized in the Table 19.

The reasons for returning specific status codes in a N-EVENT-REPORT response are summarized in the Table below:

Table 20

Printer SOP Class N-EVENT-REPORT Response Status Reasons

Service Status	Further Meaning	Error Code	Reasons
Success	Success	0000	The notification event has been successfully received.
Failure	No Such Event Type	0113H	An invalid Event Type ID was supplied in the N-EVENT-REPORT request.
Failure	Processing Failure	0110H	An internal error occurred during processing of the N-EVENT-REPORT. A short description of the error will be returned in Error Comment (0000, 0902).

4.2.1.3.3.5 SOP Specific Conformance for the Film Session SOP Class

Print AE supports the following DIMSE operations for the Film Session SOP Class:

- N-CREATE
- N-DELETE

Details of the supported attributes and status handling behavior are described in the following subsections.

4.2.1.3.3.5.1 Film Session SOP Class Operations (N-CREATE)

The attributes supplied in an N-CREATE Request are listed in the Table below:

Table 21

Film Session SOP Class N-CREATE Request Attributes

Attribute Name	Tag	VR	Value	Presence of Value	Source
Number of Copies	(2000,0010)	IS	[1, 100]	ALWAYS	CONFIG
Print Priority	(2000,0020)	CS	LOW, MED,HIGH	ALWAYS	CONFIG
Medium Type	(2000,0030)	CS	BLUE FILM, CLEAR FILM, PAPER	ALWAYS	CONFIG
Film	(2000,0040)	CS	MAGAZINE, PROCESSOR	ALWAYS	CONFIG

following subsections.

4.2.1.3.3.6.1 Film Box SOP Class Operations (N-CREATE)

The attributes supplied in an N-CREATE Request are listed in the Table below:

**Table 24
Film Box SOP Class N-CREATE Request Attributes**

Attribute Name	Tag	VR	Value	Presence of Value	Source
Image Display Format	(2010,0010)	CS	PORTRAIT: STANDARD\1,1 STANDARD\1,2 STANDARD\1,3 STANDARD\2,1 STANDARD\2,2 STANDARD\2,3 STANDARD\2,4 STANDARD\3,3 STANDARD\3,4 STANDARD\3,5 STANDARD\3,6 STANDARD\4,4 STANDARD\4,5 STANDARD\4,6 STANDARD\4,7 STANDARD\4,8 STANDARD\5,5 STANDARD\5,6 STANDARD\5,7 STANDARD\5,8 STANDARD\6,6 STANDARD\6,7 STANDARD\6,8 STANDARD\6,9 STANDARD\6,10 STANDARD\7,7 STANDARD\7,8 STANDARD\7,9	ALWAYS	CONFIG

		<p>STANDARD\7,10</p> <p>STANDARD\8,8</p> <p>STANDARD\8,9</p> <p>STANDARD\8,10</p> <p>LANDSCAPE:</p> <p>STANDARD\1,1</p> <p>STANDARD\2,1</p> <p>STANDARD\3,1</p> <p>STANDARD\1,2</p> <p>STANDARD\2,2</p> <p>STANDARD\3,2</p> <p>STANDARD\4,2</p> <p>STANDARD\3,3</p> <p>STANDARD\4,3</p> <p>STANDARD\5,3</p> <p>STANDARD\6,3</p> <p>STANDARD\4,4</p> <p>STANDARD\5,4</p> <p>STANDARD\6,4</p> <p>STANDARD\7,4</p> <p>STANDARD\8,4</p> <p>STANDARD\5,5</p> <p>STANDARD\6,5</p> <p>STANDARD\7,5</p> <p>STANDARD\8,5</p> <p>STANDARD\6,6</p> <p>STANDARD\7,6</p> <p>STANDARD\8,6</p> <p>STANDARD\9,6</p> <p>STANDARD\10,6</p> <p>STANDARD\7,7</p> <p>STANDARD\8,7</p> <p>STANDARD\9,7</p> <p>STANDARD\10,7</p> <p>STANDARD\8,8</p> <p>STANDARD\9,8</p>		
--	--	---	--	--

			STANDARD\10,8		
Referenced Film Session Sequence	(2010,0500)	SQ			
>Referenced SOP Class UID	(0008,1150)	UI	1.2.840.10008.5.1.1.1	ALWAYS	AUTO
>Referenced SOP Instance UID	(0008,1155)	UI	From created Film Session SOP Instance	ALWAYS	AUTO
Film Orientation	(2010,0040)	CS	PORTRAIT or LANDSCAPE	ALWAYS	CONFIG
Film Size ID	(2010,0050)	CS	8INX10IN 8_5INX11IN 10INX12IN 10INX14IN 11INX14IN 11INX17IN 14INX14IN 14INX17IN 24CMX24CM 24CMX30CM A4 A3	ALWAYS	CONFIG
Magnification Type	(2010,0060)	CS	REPLICATE, BILINEAR, CUBIC or NONE	ALWAYS	CONFIG
Max Density	(2010,0130)	US	0 .. 65535	ANAP	CONFIG
Min Density	(2010,0120)	US	0 .. 65535	ANAP	CONFIG
Trim	(2010,0140)	CS	YES or No	ALWAYS	CONFIG
Configuration Information	(2010,0150)	ST	User defined text	ANAP	USER

The behavior of Print AE when encountering status codes in a N-CREATE response is summarized in the Table below:

Table 25
Film Box SOP Class N-CREATE Response Status Handling Behavior

Service Status	Further Meaning	Error Code	Behavior
Success	Success	0000	The SCP has completed the operation successfully.
Warning	Requested Min Density or Max Density outside of printer's operating range	B605H	The N-CREATE operation is considered successful.
Warning	Any other warning	xxxx	The N-CREATE operation is considered successful.
Failure	Any failure	xxxx	The Association is aborted using A-ABORT and the print-job is marked as failed. The status meaning is logged and reported to the user.

4.2.1.3.3.6.2 Film Box SOP Class Operations (N-ACTION)

An N-ACTION Request is issued to instruct the Print SCP to print the contents of the Film Box. The Action Reply argument in an N-ACTION response is not evaluated.

The behavior of Print AE when encountering status codes in a N-ACTION response is summarized in the Table below:

**Table 26
Film Box SOP Class N-ACTION Response Status Handling Behavior**

Service Status	Further Meaning	Error Code	Behavior
Success	Success	0000	The SCP has completed the operation successfully. The film has been accepted for printing.
Warning	Film Box SOP Instance hierarchy does not contain Image Box SOP Instances (empty page)	B603H	The N-ACTION operation is considered successful.
Warning	Image size is larger than Image Box size. The image has been demagnified.	B604H	The N-ACTION operation is considered successful.
Warning	Image size is larger than Image Box size. The image has been cropped to fit.	B609H	The N-ACTION operation is considered successful.
Warning	Image size or Combined Print Image Size is larger than Image Box size. The image or combined Print Image has been decimated to fit.	B60AH	The N-ACTION operation is considered successful.



M7 Series Diagnostic Ultrasound System

Warning	Any other warning	xxxx	The N-ACTION operation is considered successful.
Failure	Unable to create Print Job SOP Instance; print queue is full.	C602	The Association is aborted using A-ABORT and the print-job is marked as failed. The status meaning is logged and reported to the user.
Failure	Image size is larger than Image Box size.	C603	The Association is aborted using A-ABORT and the print-job is marked as failed. The status meaning is logged and reported to the user.
Failure	Combined Print Image Size is larger than Image Box size.	C613	The Association is aborted using A-ABORT and the print-job is marked as failed. The status meaning is logged and reported to the user.
Failure	Any other failure	xxxx	The Association is aborted using A-ABORT and the print-job is marked as failed. The status meaning is logged and reported to the user.

4.2.1.3.3.6.3 Film Session SOP Class Operations (N-DELETE)

The behavior of Print AE when encountering status codes in a N-DELETE response is summarized in the Table below:

Table 27
Printer SOP Class N-DELETE Response Status Handling Behavior

Service Status	Further Meaning	Error Code	Behavior
Success	Success	0000	The SCP has completed the operation successfully.
Warning	Any warning	xxxx	The N-DELETE operation is considered successful.
Failure	Any other failure	xxxx	The Association is aborted using A-ABORT and the print-job is marked as failed. The status meaning is logged and reported to the user.

4.2.1.3.3.7 SOP Specific Conformance for the Image Box SOP Class

Print AE supports the following DIMSE operations for the Image Box SOP Class:

- N-SET



M7 Series Diagnostic Ultrasound System

Details of the supported attributes and status handling behavior are described in the following subsections.

4.2.1.3.3.7.1 Image Box SOP Class Operations (N-SET)

The attributes supplied in an N-SET Request are listed in the Table below:

Table 28
Image Box SOP Class N-SET Request Attributes

Attribute Name	Tag	VR	Value	Presence of Value	Source
Image Position	(2020,0010)	US	[1, num_image1]	ALWAYS	AUTO
Basic Grayscale Image Sequence	(2020,0111)	SQ		If the service is configured as MONOCHROME2	
>Samples Per Pixel	(0028,0002)	US	1	ALWAYS	AUTO
>Photometric Interpretation	(0028,0004)	CS	MONOCHROME2	ALWAYS	CONFIG
>Rows	(0028,0010)	US	Depends on film size	ALWAYS	AUTO
>Columns	(0028,0011)	US	Depends on film size	ALWAYS	AUTO
>Pixel Aspect Ratio	(0028,0034)	IS	Set to zero length	VNAP	AUTO
>Bits Allocated	(0028,0100)	US	8	ALWAYS	AUTO
>Bits Stored	(0028,0101)	US	8	ALWAYS	AUTO
>High Bit	(0028,0102)	US	7	ALWAYS	AUTO
>Pixel Representation	(0028,0103)	US	0	ALWAYS	AUTO



M7 Series Diagnostic Ultrasound System

>Pixel Aspect Ratio	(0028,0034)	IS	Set to zero length	VNAP	AUTO
>Bits Allocated	(0028,0100)	US	8	ALWAYS	AUTO
>Bits Stored	(0028,0101)	US	8	ALWAYS	AUTO
>High Bit	(0028,0102)	US	7	ALWAYS	AUTO
>Pixel Representation	(0028,0103)	US	0	ALWAYS	AUTO
>Pixel Data	(7FE0,0010)	OB	Pixels of rendered film sheet	ALWAYS	AUTO

Note: 1 If the attribute of Image Display Format is (STANDARD\m, n), num_image is m*n.
The behavior of Print AE when encountering status codes in a N-SET response is summarized in the Table below:

Table 29
Image Box SOP Class N-SET Response Status Handling Behavior

Service Status	Further Meaning	Error Code	Behavior
Success	Success	0000	Image print is successful, The status code is logged and the task success is reported to the user via task management.
Warning	Image size is larger than Image Box size. The image has been demagnified.	B604H	The N-SET operation is considered successful.
Warning	Requested Min Density or Max Density outside of printer's operating range.	B605H	The N-SET operation is considered successful.
Warning	Image size is larger than Image Box size. The image has been cropped to fit.	B609H	The N-SET operation is considered successful.
Warning	Image size or Combined Print Image Size is larger than Image Box size. The image or combined Print Image has been decimated to fit.	B60AH	The N-SET operation is considered successful.
Warning	Any other warning	xxxx	The N-SET operation is considered successful.
Failure	Image size is larger than Image Box size.	C603	The Association is aborted using A-ABORT and the print-job is marked as failed. The status

			meaning is logged and reported to the user.
Failure	Insufficient memory in printer to store the image.	C605	The Association is aborted using A-ABORT and the print-job is marked as failed. The status meaning is logged and reported to the user.
Failure	Combined Print Image Size is larger than Image Box size.	C613	The Association is aborted using A-ABORT and the print-job is marked as failed. The status meaning is logged and reported to the user.
Failure	Any other failure	xxxx	The Association is aborted using A-ABORT and the print-job is marked as failed. The status meaning is logged and reported to the user.

4.2.1.3.4 Activity – Send Find Request

4.2.1.3.4.1 Description and Sequencing of Activities

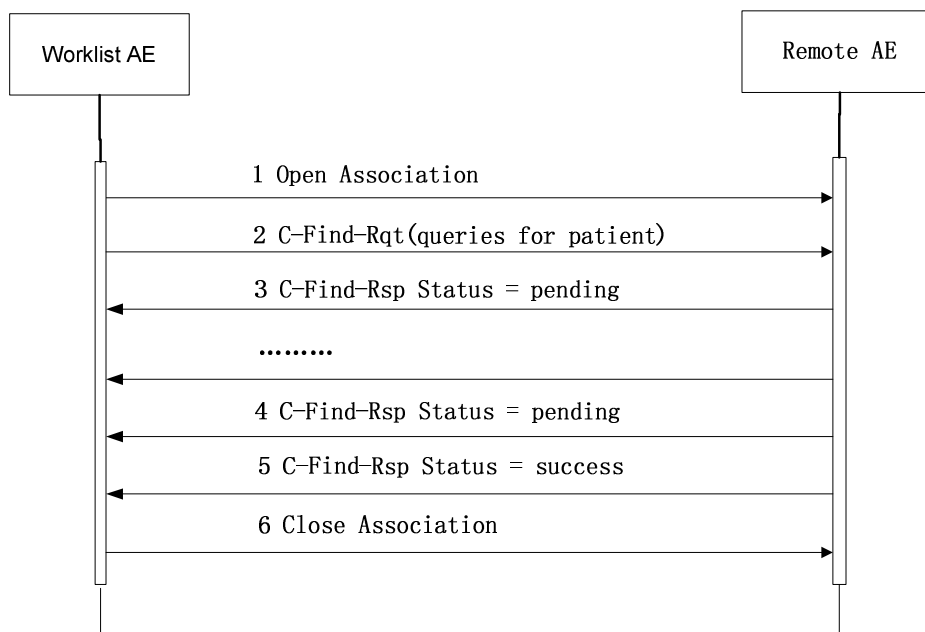

Figure 5

attributes.

3. The remote AE returns a C-FIND response containing the requested attributes of the first matching Item.
4. The remote AE returns another C-FIND response containing the requested attributes of the second matching Item. And then another one.
5. When the remote AE returns all the C-FIND responses with status Success indicating that no further matching Items exist.
6. The C-Find AE closes the association with the remote AE.

4.2.1.3.4.2 Proposed Presentation Contexts

Table 30



M7 Series Diagnostic Ultrasound System

	request		
--	---------	--	--



M7 Series Diagnostic Ultrasound System

Worklist Request Identifier

ATTRIBUTE	VR	ATTRIBUTE NAME	MATCHING KEYS	RETURN KEYS
Module: Patient Identification Module (M)				
(0010,0010)	PN	Patient's Name	configurable	X (DI)
(0010,0020)	LO	Patient ID	configurable	X(DI)
(0010,1000)	LO	Other Patient IDs		X (DI)
Module: Patient Demographic Module (M)				
(0010,0030)	DA	Patient's Birth Date		X(DI)
(0010,0032)	TM	Patient's Birth Time		X(DI)
(0010,0040)	CS	Patient's Sex		X(DI)
(0010,1020)	DS	Patient's Size		X (DI)
(0010,1030)	DS	Patient's Weight		X (DI)
(0010,2160)	SH	Ethnic Group		X (DI)
(0010,4000)	LT	Patient Comments		X (DI)
(0040,3001)	LO	Confidentiality constraint on patient data Description		X (DI)
Module: Patient Medical Module (M)				
(0010,2000)	LO	Medical Alerts		X (DI)
(0010,2110)	LO	Contrast Allergies		X (DI)
(0010,21B0)	US	Additional Patient's History		X (DI)
(0010,21C0)	US	Pregnancy Status		X (DI)
(0010,21D0)	DA	Last Menstrual Date		X (DI)
(0038, 0050)	LO	Special Needs		X (DI)
(0038, 0500)	LO	Patient State		X (DI)
Module: Visit Relationship Module (M)				
(0008,1120)	SQ	Referenced Patient Sequence		X (DI)
Module: Visit Identification Module (M)				
(0038,0010)	LO	Admission ID		X (DI)
Module: Visit Status Module (M)				
(0038,0300)	LO	Current Patient		X (DI)



M7 Series Diagnostic Ultrasound System

		Location		
Module: Visit Admission Module (M)				
(0008,1080)	LO	Admitting Diagnosis Description		X (DI)
Module: Scheduled Procedure Step Module (M)				
(0040,0100)	SQ	Scheduled Procedure Step Sequence		X (DI)
>(0008,0060)	CS	Modality	Configurable and the default set to last used value	
>(0032,1070)	LO	Requested Contrast Agent		X (DI)
>(0040,0001)	AE	Scheduled Station AE Title	configurable and the default set to your AE title	X (DI)
>(0040,0002)	DA	Scheduled Procedure Step Start Date	configurable and the default set to today's date	X(DI)
>(0040,0003)	TM	Scheduled Procedure Step Start Time		X (DI)
>(0040,0004)	DA	Scheduled Procedure Step End Date		X (DI)
>(0040,0005)	TM	Scheduled Procedure Step End Time		X (DI)
>(0040,0006)	PN	Scheduled Performing Physician's Name		X (DI)
>(0040,0007)	LO	Scheduled Procedure Step Description		X(DI)
>(0040,0008)	SQ	Scheduled Protocol Code Sequence		X (DI)
>>(0008,0100)	SH	Code Value		X (DI)
>>(0008,0102)	SH	Coding Scheme Designator		X (DI)
>>(0008,0103)	SH	Coding Scheme Version		X (DI)
>>(0008,0104)	LO	Code Meaning		X (DI)
>(0040,0009)	SH	Scheduled Procedure		X (DI)



M7 Series Diagnostic Ultrasound System

		Step ID		
>(0040,0010)	SH	Scheduled Station Name		X (DI)
>(0040,0011)	SH	Scheduled Procedure Step Location		X (DI)
>(0040,0012)	LO	Pre-Medication		X (DI)
> (0040,0020)	CS	Scheduled Procedure Step Status		X (DI)
> (0040,0400)	LT	Comments on the Scheduled Procedure Step		X (DI)
Module: Requested Procedure Module (M)				
(0008,1110)	SQ	Referenced Study Sequence		X (DI)
> (0008,1150)	UI	Referenced SOP Class UID		X (DI)
> (0008,1155)	UI	Referenced SOP Instance UID		X (DI)
(0020,000D)	UI	Study Instance UID		X (DI)
(0032,1060)	LO	Requested Procedure Description		X (DI)
(0032,1064)	SQ	Requested Procedure Code Sequence		X (DI)
> (0008,0100)	SH	Code Value		X (DI)
> (0008,0102)	SH	Coding Scheme Designator		X (DI)
>(0008,0103)	SH	Coding Scheme Version		X (DI)
>(0008,0104)	LO	Code Meaning		X (DI)
(0040,1001)	SH	Requested Procedure ID	configurable	X (DI)
(0040,1003)	SH	Requested Procedure Priority		X (DI)
(0040,1004)	LO	Patient Transport Arrangements		X (DI)
(0040,1400)	LT	Requested Procedure Comments		X (DI)

Module: Imaging Service Request Module (M)				
(0008,0050)	SH	Accession Number	configurable	X (DI)
(0008,0090)	PN	Referring Physician's Name		X (DI)
(0032,1032)	PN	Requesting Physician		X (DI)
(0032,1033)	LO	Requesting Service		X (DI)
(0040,2400)	LT	Imaging Service Request Comments		X (DI)
Module: SOP Common Module (M)				
(0008,0005)	CS	Specific Character Set		X (DI)
Module: Additional Attributes Module (M)				
(0008,0032)	TM	Acquisition Time		X (DI)

The convention used for Matching Keys is:

X - Return keys. An " X " indicates that MODALITY supplies this attribute as a Return Key with zero length for Universal Matching.

DI – Display to the user

4.2.1.3.5 Activity – Send MPPS Request

4.2.1.3.5.1 Description and Sequencing of Activities

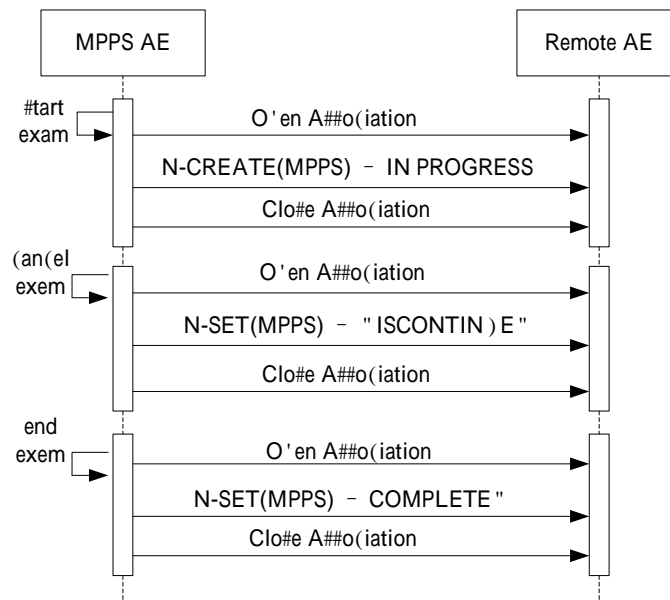

Figure 6

Sequencing of Activity – MPPS progress

Note: The Cancel and End Exam commands are mutually exclusive. They are both represented here for illustration purposes only. Actual workflow uses one or the other for a

given exam.

For each exam step transfer, an attempt will be made to transmit it to the selected remote AE. If it fails, user can restart the failed task by pressing “Retry” Button on the DICOM task dialog.

4.2.1.3.5.2 Proposed Presentation Contexts

**Table 34
Proposed Presentation Contexts for MPPS AE**

Presentation Context Table					
Abstract Syntax		Transfer Syntax		Role	Extended Negotiation
Name	UID	Name	UID		
Modality Performed Procedure Step SOP Class	1.2.840.10008.3.1.2.3.3	Implicit VR Little Endian	1.2.840.10008.1.2	SCU	None
		Explicit VR Little Endian	1.2.840.10008.1.2.1	SCU	None
		Explicit VR Big Endian	1.2.840.10008.1.2.2	SCU	None

MPPS-SCU will propose Presentation Contexts for the SOP Classes listed above. For these SOP Class, MPPS-SCU will propose multiple Presentation Contexts, one for each of the supported Transfer Syntaxes.

If MPPS AE is offered a choice of Transfer Syntaxes in the accepted Presentation Contexts, it will apply the first encountered to use for the MPPS AE operation.

4.2.1.3.5.3 SOP Specific Conformance

MPPS AE provides Standard Conformance to the MPPS Service Class.

MPPS-SCU will behave as described in the Table below in response to the status returned in the N-Create or N-Set response command message.

**Table 35
MPPS Response Status Handling Behavior**

Service Status	Further Meaning	Error Code	Behavior(As scu)
Success	The performed procedure steps are successfully transferred	0000	The N-SET operation is considered successful and the MPPS uid is saved in system.
Warning	The association is aborted using A-ABORT and the transfer is marked as failed. The reason is logged and reported to the user.	B60x	



M7 Series Diagnostic Ultrasound System

Failed	The association is aborted using A-ABORT and the transfer job is marked as failed. The reason is logged and reported to the user.	C60x	The association is aborted using A-ABORT and the MPPS uid isn't saved.
--------	---	------	--

Table below provides a description of the MPPS N-CREATE and N-SET request identifiers sent by ultrasound system. Empty cells in the N-CREATE and N-SET columns indicate that the attribute is not sent. An “x” indicates that an appropriate value will be sent. A “Zero length” attribute will be sent with zero length.

Table 36

MPPS N-CREATE / N-SET Request Identifier

Attribute Name	Tag	Req. Type N-CREATE	Req. Type N-SET
Module: Performed Procedure Step Relationship Module (M)			
Referenced Patient Sequence	(0008,1120)	2 (Default is set to null)	Not allowed
Patient's Name	(0010,0010)	2	Not allowed
Patient ID	(0010,0020)	2	Not allowed
Patient's Birth Date	(0010,0030)	2	Not allowed
Patient's Sex	(0010,0040)	2	Not allowed
Scheduled Step Attribute Sequence	(0040,0270)	1	Not allowed
>Accession Number	(0008,0050)	2	Not allowed
>Referenced Study Sequence	(0008,1110)	2	Not allowed
>Study Instance UID	(0020,000D)	1	Not allowed
>Requested Procedure Description	(0032,1060)	2	Not allowed
>Scheduled Procedure Step Description	(0040,0007)	2	Not allowed
>Scheduled Protocol Code Sequence	(0040,0008)	2	Not allowed
>Scheduled Procedure Step ID	(0040,0009)	2	Not allowed
>Requested Procedure ID	(0040,1001)	2	Not allowed
Module: Image Acquisition Results Module (M)			
Modality	(0008,0060)	1	Not allowed
Study ID	(0020,0010)	2	Not allowed
Performed Protocol Code Sequence	(0040,0260)	2 (Default is set to null)	3



M7 Series Diagnostic Ultrasound System

Performed Series Sequence	(0040,0340)	2	3
>Retrieve AE Title	(0008,0054)	2 (Default is set to null)	2
>Series Description	(0008,103E)	2 (Default is set to null)	2
>Performing Physician's Name	(0008,1050)	2	2
>Operators' Name	(0008,1070)	2	2
>Referenced Image Sequence	(0008,1140)	2	2
>Protocol Name	(0018,1030)	1	1
>Series Instance UID	(0020,000E)	1	1
>Referenced Non-Image Composite SOP Instance Sequence	(0040,0220)	2 (Default is set to null)	2
Module: Billing And Material Management Code Module (M)			
Billing Procedure Step Sequence	(0040,0320)	3	3
Film Consumption Sequence	(0040,0321)	3	3
Billing Supplies and Devices Sequence	(0040,0324)	3	3
Module: Performed Procedure Step Information Module (M)			
Procedure Code Sequence	(0008,1032)	2 (Default is set to null)	3
Performed Station AE Title	(0040,0241)	1	Not allowed
Performed Station Name	(0040,0242)	2 (Default is set to null)	Not allowed
Performed Location	(0040,0243)	2 (Default is set to null)	Not allowed
Performed Procedure Step Start Date	(0040,0244)	1	Not allowed
Performed Procedure Step Start Time	(0040,0245)	1	Not allowed
Performed Procedure Step End Date	(0040,0250)	2 (Default is set to null)	3
Performed Procedure Step End Time	(0040,0251)	2	3
Performed Procedure Step Status	(0040,0252)	1	3
Performed Procedure Step ID	(0040,0253)	1	Not allowed
Performed Procedure Step Description	(0040,0254)	2 (Default is set to null)	3
Performed Procedure Type Description	(0040,0255)	2 (Default is set to null)	3

Performed Procedure Step Discontinuation Reason Code Sequence	(0040,0281)	3	3
Module: SOP Common Module (M)			
Specific Character Set	(0008,0005)	1C (Required if an extended or replacement character set is used)	Not allowed

4.2.1.3.6 Activity – Query/Retrieve from Remote AE

4.2.1.3.6.1 Description and Sequencing of Activities for SCU

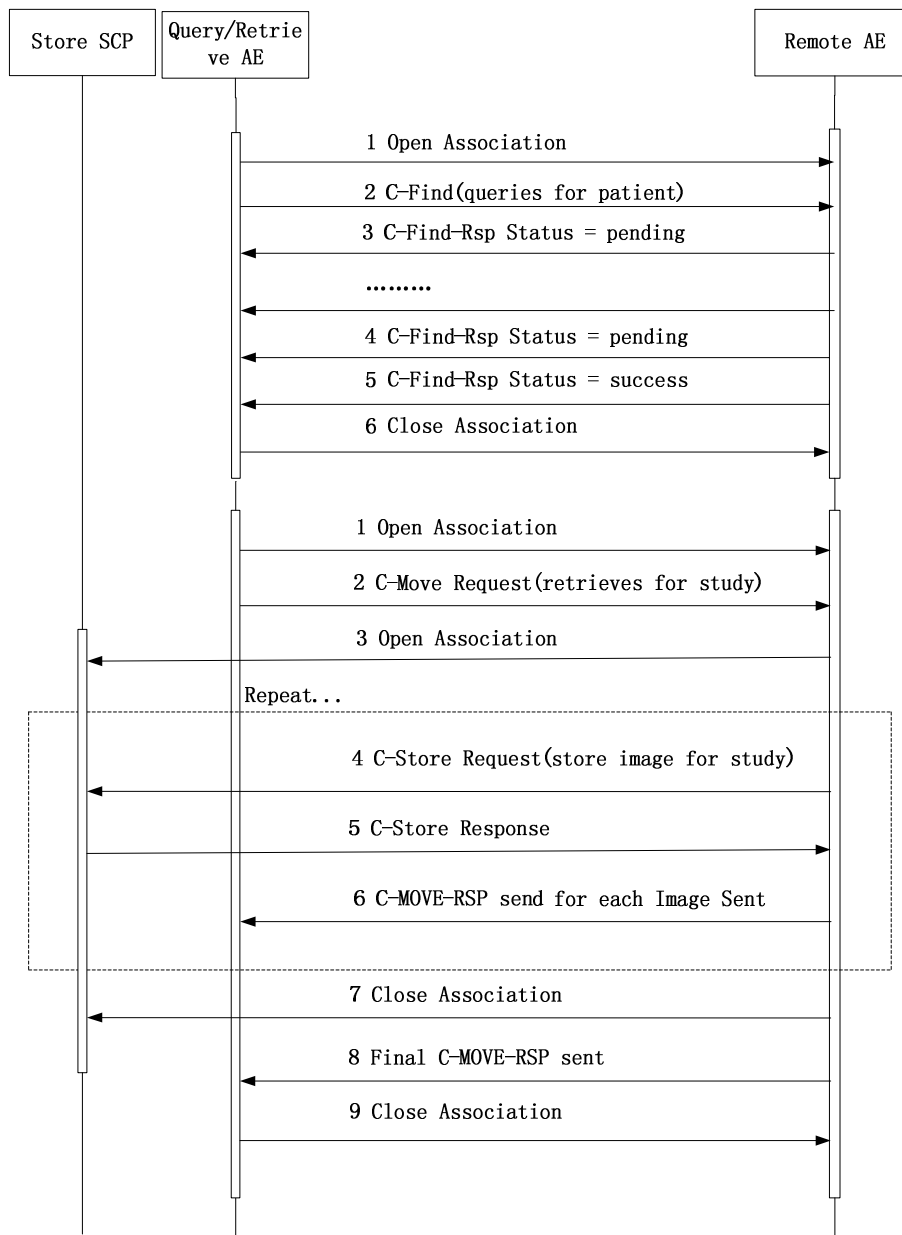

Figure 7

Sequencing of Activity – Query/Retrieve progress

The associated Real-World activity is a C-Find request initiated by the user. The user



M7 Series Diagnostic Ultrasound System

	Unable to process	CXXX	(0000,0901) (0000,0902)	notify message is displayed: The remote server error.
Canceling	Matching terminated due to Cancel request	FE00	None	
Success	Matching is complete - No final Identifier is supplied	0000	None	Patient lists show on the UI
Pending	Matches are continuing - Current Match is supplied and any Optional Keys were supported in the same manner as Required Keys	FF00	Identifier	/
	Matches are continuing - Warning that one or more Optional Keys were not supported for existence and/or matching for this identifier	FF01	Identifier	/

The ultrasound system supports the following query levels:

- Study

The Query/Retrieve AE interprets following status codes

Table 39
C-Move Response Status Handling Behavior

Service Status	Meaning	Protocol Codes	Related Fields	Behavior (as SCU)
Refused	Refused Out of Resources	A700	(0000,0902)	The association is aborted using A-ABORT and a notify message is displayed: The remote server error.
Failed	Identifier does not match SOP Class	A900	(0000,0901) (0000,0902)	
	Unable to process	CXXX	(0000,0901) (0000,0902)	
Canceling	Matching terminated due to Cancel request	FE00	None	
Success	Matching is complete - No final Identifier is supplied	0000	None	Image retrieve is successful, Patient lists show on the UI
Pending	Matches are continuing - Current Match is supplied and any Optional Keys were supported in the same manner as Required Keys	FF00	Identifier	/
	Matches are continuing - Warning	FF01	Identifier	/



	that one or more Optional Keys were not supported for existence and/or matching for this identifier			
--	---	--	--	--

4.2.1.3.6.3.2 Study Root Query/Retrieve Attributes

4.2.1.3.6.3.3 Supported Matching

Following are the types of matching that can be request by the implementation:

- Single Value matching
- Universal Matching
- Wild Card Matching
- Range of date, Range of Time

The user can filter the downloaded C-FIND result, to view a limited set of the result.

4.2.1.3.6.3.4 Study Level

This section defines the keys at the Study Level of the Study Root Query/Retrieve Information Model that are supported by this implementation.

**Table 40
STUDY LEVEL ATTRIBUTES**

MODULE: STUDY ROOT INFORMATION MODEL (M)					
Attribute	VR	Type	Attribute Name	Value	Matching keys
Module: Study Root Information Model (M)					
(0008,0020)	DA	R	Study Date		DA(SK)
(0008,0030)	TM	R	Study Time		N
(0010,0010)	PN	R	Patient's Name		*(SK)
(0010,0020)	LO	R	Patient ID		S(SK)
(0008,0050)	SH	R	Accession Number		*(SK)
(0010,0030)	DA	O	Patient's Birth Date		S(SK)
(0010,0040)	CS	O	Patient's Sex		S(SK)
(0020,0010)	SH	R	Study ID		S(SK)
(0020,000D)	UI	U	Study Instance UID		N
(0008,0061)	CS	O	Modalities in Study	US	N
(0008,0090)	PN	O	Referring Physician's Name		N
(0008,1030)	LO	O	Study Description		N
(0008,1032)	SQ	O	Procedure Code Sequence		N
(0008,1060)	PN	O	Name of Physician(s) Reading Study		N
(0008,1080)	LO	O	Admitting Diagnoses Description		N
(0008,1110)	SQ	O	Referenced Study Sequence		N
(0008,1120)	SQ	O	Referenced Patient Sequence		N
(0010,0021)	LO	O	Issuer of Patient ID		N
(0010,0032)	TM	O	Patient's Birth Time		N



M7 Series Diagnostic Ultrasound System

(0010,1000)	LO	O	Other Patient IDs		N
(0010,1001)	PN	O	Other Patient Names		N
(0010,1010)	AS	O	Patient's Age		N
(0010,1020)	DS	O	Patient's Size		N
(0010,1030)	DS	O	Patient's Weight		N
(0010,2160)	SH	O	Ethnic Group		N
(0010,2180)	SH	O	Occupation		N
(0010,21B0)	LT	O	Additional Patient History		N
(0010,4000)	LT	O	Patient Comments		N
(0020,1070)	IS	O	Other Study Numbers		N
(0020,1200)	IS	O	Number of Patient Related Studies		N
(0020,1202)	IS	O	Number of Patient Related Series		N
(0020,1204)	IS	O	Number of Patient Related Instances		N
(0020,1206)	IS	O	Number of Study Related Series		N
(0020,1208)	IS	O	Number of Study Related Instances		N
(4008,010C)	PN	O	Interpretation Author		N
Module: Additional Attributes Module (O)					
(0008,0062)	UN	O	SOP Classes in Study		N

4.2.1.3.6.3.5 Series Level Attributes

Table 41

SERIES LEVEL ATTRIBUTES

ATTRIBUTE	VR	TYP E	ATTRIBUTE NAME	VAL UE	MATCHIN GKEYS
Module: Study Root Information Model (M)					
(0020,000D)	UI	U	Study Instance UID		S
(0020,000E)	UI	U	Series Instance UID		N
(0008,0060)	CS	R	Modality		N
(0020,0011)	IS	R	Series Number		N
(0020,1209)	IS	O	Number of Series Related Instances		N
Module: Additional Attributes Module (O)					
(0008,0021)	DA	O	Series Date		N
(0008,0031)	TM	O	Series Time		N

4.2.1.3.6.3.6 Composite Object Instance Level

Table 42

COMPOSITE OBJECT INSTANCE LEVEL ATTRIBUTES

ATTRIBUTE	VR	TYP E	ATTRIBUTE NAME	VALUE	MATCHIN GKEYS
Module: Study Root Information Model (M)					
(0020,000D)	UI	U	Study Instance UID		S
(0020,000E)	UI	U	Series Instance UID		S
(0008,0018)	UI	U	SOP Instance UID		N
(0020,0013)	IS	R	Instance Number		N
Module: Additional Attributes Module (O)					
(0008,0016)	UI	O	SOP Class UID		N
(0008,001A)	UI	O	Related General SOP Class UID		N
(0008,3001)	SQ	O	Alternate Representation Sequence		N
>(0008,1150)	UI	O	Referenced SOP Class UID		N
>(0008,1155)	UI	O	Referenced SOP Instance UID		N
>(0020,000E)	UI	O	Series Instance UID		N
>(0040,A170)	SQ	O	Purpose of Reference Code Sequence		N
>>(0008,0100)	SH	O	Code Value		N
>>(0008,0102)	SH	O	Coding Scheme Designator		N
>>(0008,0103)	SH	O	Coding Scheme Version		N
>>(0008,0104)	LO	O	Code Meaning		N
(0040,A043)	SQ	O	Concept Name Code Sequence		N
>(0008,0100)	SH	O	Code Value		N
>(0008,0102)	SH	O	Coding Scheme Designator		N

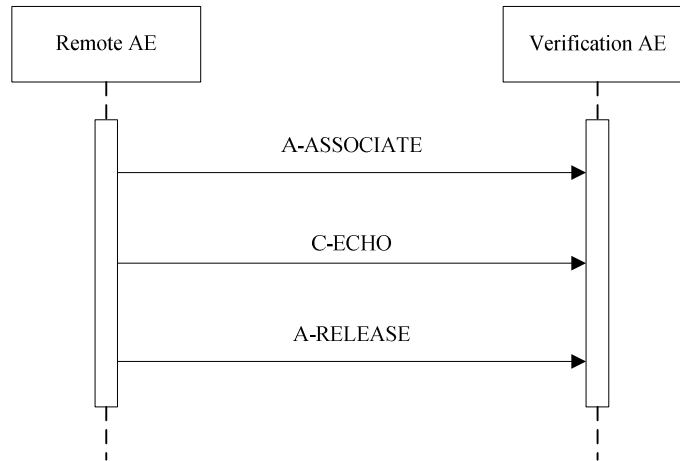

Figure 8
Sequencing of Activity – Receive Echo Request

4.2.1.4.1.2 Accepted Presentation Contexts

It will accept Presentation Contexts as shown in the following table:

Table 43
Proposed Presentation Contexts for Activity Verification

Presentation Context Table					
Abstract Syntax		Transfer Syntax		Role	Extended Negotiation
Name	UID	Name	UID		
Verification	1.2.840.10008.1.1	Implicit VR Little Endian	1.2.840.10008.1.2	SCP	None
		Explicit VR Little Endian	1.2.840.10008.1.2.1	SCP	None
		Explicit VR Big Endian	1.2.840.10008.1.2.2	SCP	None

4.2.1.4.1.3 SOP Specific Conformance

The Application conforms to the definition of a Verification SCP in accordance with the DICOM Standard.

4.2.1.4.2 Activity – Receive Storage

4.2.1.4.2.1 Description and Sequencing of Activities

The system could act as Storage SCP in Query/Retrieve, otherwise couldn't. A possible sequence of interactions between the Storage AE (as SCP) and a remote AE is illustrated in the Figure 7.

4.2.1.4.2.2 Accepted Presentation Contexts

The Storage AE (as SCP) will accept Presentation Contexts as shown in the Table below.



M7 Series Diagnostic Ultrasound System

Table 44

Proposed Presentation Contexts for Storage

Capture Image Storage	08.5.1.4.1.1.7	Explicit VR Little Endian	1.2.840.10008.1.2.1	SCP	None
		JPEG Lossy, Baseline Sequential with Huffman Coding (Process 1)	1.2.840.10008.1.2.4.50	SCP	None
		Explicit VR Big Endian	1.2.840.10008.1.2.2	SCP	None
		JPEG Lossless, Non-Hierarchical, First-Order Prediction (Process 14 [Selection Value 1])	1.2.840.10008.1.2.4.70	SCP	None
		RLE Lossless	1.2.840.10008.1.2.5	SCP	None
		JPEG 2000 Image Compression (Lossless Only)	1.2.840.10008.1.2.4.90	SCP	None
		JPEG 2000 Image Compression	1.2.840.10008.1.2.4.91	SCP	None
Comprehensive Structured Report Storage	1.2.840.10008.5.1.4.1.1.88.33	Implicit VR Little Endian	1.2.840.10008.1.2	SCP	None
		Explicit VR Little Endian	1.2.840.10008.1.2.1	SCP	None
		JPEG Lossy, Baseline Sequential with Huffman Coding (Process 1)	1.2.840.10008.1.2.4.50	SCP	None
		Explicit VR Big Endian	1.2.840.10008.1.2.2	SCP	None
		JPEG Lossless, Non-Hierarchical, First-Order Prediction (Process 14 [Selection Value 1])	1.2.840.10008.1.2.4.70	SCP	None
		RLE Lossless	1.2.840.10008.1.2.5	SCP	None
		JPEG 2000 Image Compression (Lossless Only)	1.2.840.10008.1.2.4.90	SCP	None
JPEG 2000 Image Compression	1.2.840.10008.1.2.4.91	SCP	None		

4.2.1.4.2.3 SOP Specific Conformance

The Application conforms to the definition of a Storage SCP in accordance with the DICOM Standard.

4.2.1.4.3 Activity – Receive Storage Commitment

4.2.1.4.3.1 Description and Sequencing of Activities

A possible sequence of interactions between the Storage Commitment AE and a remote AE is illustrated in the Figure 3

Sequencing of Activity – Send Storage Request.

4.2.1.4.3.2 Accepted Presentation Contexts

The Storage Commitment AE will accept Presentation Contexts as shown in the Table below.

Table 45
Acceptable Presentation Contexts for
Activity Receive Storage Commitment Response

Presentation Context Table					
Abstract Syntax		Transfer Syntax		Role	Ext. Neg.
Name	UID	Name List	UID List		
Storage Commitment Push Model	1.2.840.10008.1.2.0.1	Implicit VR Little Endian	1.2.840.10008.1.2	SCU	None
		Explicit VR Little Endian	1.2.840.10008.1.2.1	SCU	None
		Explicit VR Big Endian	1.2.840.10008.1.2.2	SCU	None

The Storage Commitment AE will only accept the SCU role within a Presentation Context for the Storage Commitment Push Model SOP Class.

4.2.1.4.3.3 SOP Specific Conformance

4.2.1.4.3.3.1 Storage Commitment Operations (N-ACTION)

The Storage Commitment AE will request storage commitment for the configured device. The behavior of Storage Commitment AE when receiving N-Action response status codes is summarized in the Table below:

Table 46
Storage Commitment N-ACTION Response Status Handlin



Association aborted by the SCP or network layers	The send job is marked as failed.
--	-----------------------------------

4.2.1.4.3.3.2 Storage Commitment Tags (N-ACTION)

The Storage Commitment AE will request storage commitment using the following tags

NOTE: Storage Commitment may only be automatically requested upon successful completion of an end exam storage task,

Table 48

Storage Commitment N-Action-Request Message Contents

Action Type Name	Event Type ID	Attribute	Tag
N-ACTION-RQ (M)	1	Requested SOP Class UID	(0000,0003)
		Requested SOP Instance UID	(0000,1001)
Module: Additional Attributes Module (O)	3	Instance Creation Date	(0008,0012)
		Instance Creation Time	(0008,0013)
Request Storage Commitment	1	Transaction UID	(0008,1195)
		Referenced SOP Sequence	(0008,1199)
		>Referenced SOP Class UID	(0008,1150)
		>Referenced SOP Instance UID	(0008,1155)

4.2.1.4.3.3.3 Storage Commitment Notifications (N-EVENT-REPORT)

The reasons for returning specific status codes in a N-EVENT-REPORT response are summarized in the Table below.

Table 49

Storage Commitment N-EVENT-REPORT Response Status Reasons

Service Status	Further Meaning	Error Code
Success	N-EVENT-REPORT message operate success.	0000
Failed	N-EVENT-REPORT message operate failed.	0110

4.2.1.4.3.3.4 Storage Commitment Tags (N-EVENT- REPORT)

Tags supported for receiving an N-Event-Report message.

Table 50

Storage Commitment N-Event-Report Message Contents

EVENT TYPE NAME	EVE NT TYPE ID	ATTRIBUTE	TAG	REQUIRE MENT TYPE SCP
Storage Commitment Request	1	Transaction UID	(0008,1195)	1
		Referenced SOP Sequence	(0008,1199)	1
		>Referenced SOP Class UID	(0008,1150)	1



Successful		>Referenced SOP Instance UID	(0008,1155)	1
Storage Commitment Request Complete – Failures Exist	2	Transaction UID	(0008,1195)	1
		Referenced SOP Sequence	(0008,1199)	1
		>Referenced SOP Class UID	(0008,1150)	1
		>Referenced SOP Instance UID	(0008,1155)	1
		Failed SOP Sequence	(0008,1198)	1
		>Referenced SOP Class UID	(0008,1150)	1
		>Referenced SOP Instance UID	(0008,1155)	1
		>Failure Reason	(0008,1197)	1

4.3 Network Interface

4.3.1 Supported Communications Stacks

Modality DICOM AEs provide DICOM 3.0 TCP/IP Network Communication Support as defined in Part 8 of the DICOM Standard.

4.3.2 TCP/IP Stack

Modality DICOM AEs inherit their TCP/IP stack from the Windows XP Operating System upon which they execute.

4.3.3 Physical Network Interface

Modality supports a single network interface. One of the following physical network interfaces will be available depending on installed hardware options:

Table 51
Supported Physical Network Interfaces

ETHERNET 1000BASET
Ethernet 100baseT
Ethernet 10baseT

4.3.4 Additional Protocols

Modality does not support additional protocols.

4.4 Configuration

The Configuration Utility allows the service engineer to set and maintain configuration parameters of local and remote DICOM application entities.

4.4.1 AE Title/Presentation Address Mapping

This mapping (including IP and port numbers) is defined during the system Network Configuration procedure.

4.4.2 Configurable Parameters

Localhost DICOM Service Property(Including SCU and SCP):

AE Title
Port
PDU

Server Setting:

Device
IP address

Storage:

Device, Service name, AE Title and Port.
Timeout.
Maximum retries. (default value is 3)
Interval Time (In this version, this parameter is not usable.)
Compression Mode, Compression Ratio.
Color Mode (Color, Mixed, or Gray).
Cine Zoom Mode (original or 640*480)
Allow Multiframe(Enable or not)
Max Framerate(options(25, 30, 35, full), or other inputed valid value)
3D/4D(cine or volume)
SR Storage Option(Attach SR when Store Images, Only Store SR, or Not Store SR)
Default Service Status (Y/N)

Print:



M7 Series Diagnostic Ultrasound System

Device, Service name, AE Title and Port .

Timeout.

Maximum retries. (default value is 3)

Interval Time (In this version, this parameter is not usable.)

Media Type: PAPER, CLEAR FILM, or BLUE FILM

Film Size:

8INX10IN

8_5INX11IN

10INX12IN

10INX14IN

11INX14IN

11INX17IN

14INX14IN

14INX17IN

24CMX24CM

24CMX30CM

A4

A3

Copies:1-100

Max Density: 0-65535

Min Density:0-65535

Settings: RGB or MONOCHROME2

Display Format:

PORTRAIT:

STANDARD\1,1

STANDARD\1,2

STANDARD\1,3

STANDARD\2,1

STANDARD\2,2

STANDARD\2,3

STANDARD\2,4

STANDARD\3,3

STANDARD\3,4

STANDARD\3,5

STANDARD\3,6

STANDARD\4,4

STANDARD\4,5

- STANDARD\4,6
- STANDARD\4,7
- STANDARD\4,8
- STANDARD\5,5
- STANDARD\5,6
- STANDARD\5,7
- STANDARD\5,8
- STANDARD\6,6
- STANDARD\6,7
- STANDARD\6,8
- STANDARD\6,9
- STANDARD\6,10
- STANDARD\7,7
- STANDARD\7,8
- STANDARD\7,9
- STANDARD\7,10
- STANDARD\8,8
- STANDARD\8,9
- STANDARD\8,10

LANDSCAPE:

- STANDARD\1,1
- STANDARD\1,1
- STANDARD\2,1
- STANDARD\3,1
- STANDARD\1,2
- STANDARD\2,2
- STANDARD\3,2
- STANDARD\4,2
- STANDARD\3,3
- STANDARD\4,3
- STANDARD\5,3
- STANDARD\6,3
- STANDARD\4,4
- STANDARD\5,4
- STANDARD\6,4
- STANDARD\7,4
- STANDARD\8,4

STANDARD\5,5
STANDARD\6,5
STANDARD\7,5
STANDARD\8, 5
STANDARD\6,6
STANDARD\7,6
STANDARD\8,6
STANDARD\9,6
STANDARD\10,6
STANDARD\7,7
STANDARD\8,7
STANDARD\9,7
STANDARD\10,7
STANDARD\8,8
STANDARD\9,8
STANDARD\10,8

Destination: MAGAZINE or PROCESSOR

Film Orientation: LANDSCAPE or PORTRAIT

Priority: HIGH, MED, or LOW

Configuration Info

Magnification Type: NONE, CUBIC, REPLICATE, or BILINEAR

Trim: Yes/Not

Default Status (Y/N)

WORKLIST:

Device, Service name, AE Title and Port .

Timeout.

Maximum retries, Interval Time (In this version, these two parameters are not usable.)

Default Status (Y/N)

MPPS:

Device, Service name, AE Title and Port.

Timeout,

Maximum retries (default value is 3)

Interval Time (In this version, this parameter is not usable.)

Default Status (Y/N)

5 Media Storage

5.1 Implementation Model

5.1.1 Application Data Flow

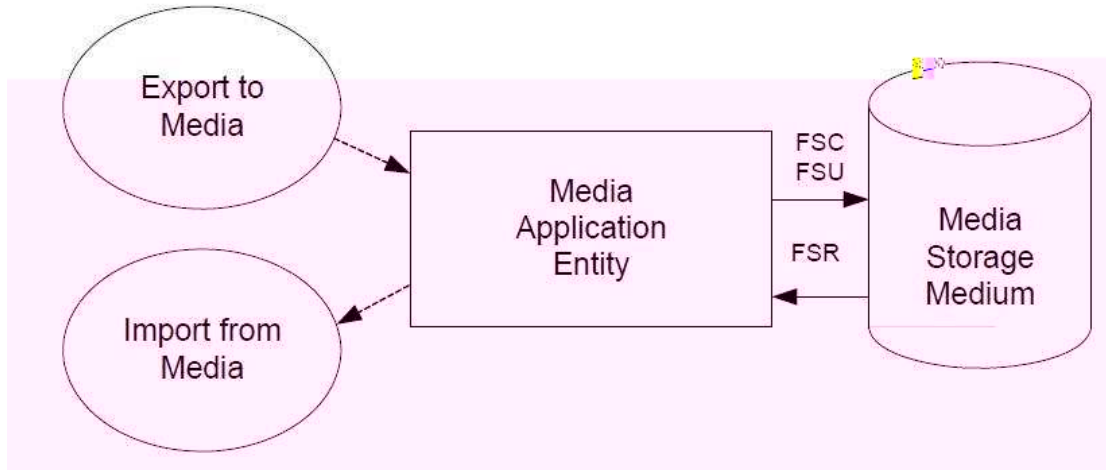

Figure 9

Application Data Flow Diagram for Media Storage

- The Media Application Entity exports Images and Structured Reports to a removable storage medium. It is associated with the local real-world activity “Backup” using the configured export selection parameters for selected patients’ data (images and / or Structured Reports).

5.1.2 Functional Definition of AE’s

5.1.2.1 Fun31013(.)-4.21067(1)0.131013(.0.13101n131013(.)-4.21067(2)8.682

5.3 Media Storage Application Profile

See Table 53 for supported Application Profiles.

5.3.1 DICOMDIR Attributes

The DICOMDIR file will contain the following attributes.

Table 55

Common Directory Information Module Attributes

ATTRIBUTE	VR	TYPE	ATTRIBUTE NAME	VALUE(S) AND COMMENTS
(0004,1130)	CS	2	File-set ID	AUTO
(0004,1200)	UL			



M7 Series Diagnostic Ultrasound System

Table 57

Study Directory Record

ATTRIBUTE	VR	TYPE	ATTRIBUTE NAME	VALUE(S) AND COMMENTS
(0004,1430)	CS	1	Directory Record Type	STUDY
(0008,0020)	DA	1	Study Date	AUTO
(0008,0030)	TM	1	Study Time	AUTO
(0020,0010)	SH	1	Study ID	AUTO
(0020,000D)	UI	1C	Study Instance UID	AUTO
(0008,0050)	SH	2	Accession Number	MWL/USER
(0008,1030)	LO	2	Study Description	If it is a scheduled exam, the value is mapped from Scheduled Procedure Step Description; If not, USER
(0008,0090)	PN		Referring Physician's Name	MWL/USER

Table 58

Series Directory Record

ATTRIBUTE	VR	TYPE	ATTRIBUTE NAME	VALUE(S) AND COMMENTS
(0004,1430)	CS	1	Directory Record Type	SERIES
(0008,0060)	CS	1	Modality	US
(0020,000E)	UI	1	Series Instance UID	AUTO
(0020,0011)	IS	1	Series Number	AUTO
(0008,0021)	DA	3	Series Date	AUTO
(0008,0031)	TM	3	Series Time	AUTO
(0008,103e)	LO		Series Description	If it is a scheduled exam, the value is mapped from Scheduled Procedure Step Description; If not, same as the value of Study Description
(0008,1050)	PN		Performing Physician's Name	MWL/USER

Table 59

Image Directory Record

ATTRIBUTE	VR	TYPE	ATTRIBUTE NAME	VALUE(S) AND COMMENTS
(0004,1430)	CS	1	Directory Record Type	IMAGE
(0004,1500)	CS	1C	Referenced File ID	AUTO
(0004,1510)	UI	1C	Referenced SOP Class UID in File	AUTO
(0004,1511)	UI	1C	Referenced SOP Instance UID in File	AUTO
(0004,1512)	UI	1C	Referenced Transfer Syntax UID in File	AUTO
(0020,0013)	IS	1	Instance Number	AUTO
(0028,0008)	IS	3	Number of Frames	AUTO(Only used for mutil-frame image)

5.4 Augmented and Private Application Profiles

No augmented/private profile is supported.

5.5 Media Configuration

None.

6 SUPPORT OF CHARACTER SETS

In addition to the default character repertoire, the Defined Terms for Specific Character Set in Table 60 are supported:

Table 60
Supported Specific Character Set Defined Terms

Character Set Description	Defined Term	System Language
ISO 8859-1	ISO_IR 100	English, French, German, Italian, Portuguese, Spanish, Finnish, Danish, Icelandic, Norwegian, Swedish
ISO 8859-5	ISO_IR 144	Russian
ISO-8859-2	ISO_IR 101	Polish, Czech
ISO-8859-9	ISO_IR 148	Turkish
Chinese	GB18030	Chinese

If the system language is configured for one of above languages, the corresponding Character Set will be used automatically. Whether or not characters are displayed correctly depends on the operating system. For example, if the system is configured for Turkish, the characters of Turkish could display correctly.

7 SECURITY

7.1 Security Profiles

None supported.

7.2 Association level security

None supported.

Any Calling AE Titles and/or IP addresses may open an Association.

7.3 Application level security

None supported.

8 ANNEXES

8.1 IOD contents

8.1.1 Created SOP Instances

None.

8.1.2 Usage of attributes from received IOD's

No SOP Class specific fields are required.

The local database makes use of the conventional identification attributes to distinguish patients, studies, series and instances. In particular, if two patients have the same value for Patient ID, Patient's Name and Patient's Sex, they will be treated as the same in the browser and the local database.

8.1.3 Attribute Mapping

Not applicable.

8.1.4 Coerced/Modified fields

No coercion is performed.

8.2 Data Dictionary of private attributes

No private attributes are defined.

8.3 Coded terminology and templates

The value for Code Meaning will be displayed for all code sequences. No local lexicon is provided to look up alternative code meanings.

8.4 Grayscale Image Consistency

Modality does not support the Grayscale Standard Display Function.

8.5 Standard extended/specialized/private sop Classes

None.

8.6 Private Transfer Syntaxes

None.

A. Appendix : OB – GYN structured reporting template

This appendix lists the DICOM Structured Report (SR) mappings used in the Obstetric and Gynecologic Structured Reports of ultrasound system SR files.

The mappings are organized in a manner similar to the DICOM SR Templates as described in PS 3.16 of the DICOM Standard. The OB-GYN Report mappings follow the DICOM SR Template TID 5000: OB-GYN Ultrasound Procedure Report, except where noted.

All private code values use the Coding Scheme Designator "MRUS".

A.1. TID (300) Measurement

This Template provides a general structure for a numeric measurement, together with evaluations of its normality and/or significance, and the inference source(s) for its value.

NO	NL	Relation with Parent	Value Type	Concept Name	Used in MODALITY	Condition	Value Set Constraint
1			NUM	\$Measurement			Units = \$Units
2	>	HAS CONCEPT MOD	CODE	EV (G-C036, SRT, "Measurement Method")			\$Method
3	>	HAS CONCEPT MOD	CODE	EV (121401, DCM, "Derivation")			\$Derivation
4	>	HAS CONCEPT MOD	CODE	EV (G-C0E3, SRT, "Finding Site")			\$TargetSite
5	>>	HAS CONCEPT MOD	CODE	EV (G-C171, SRT, "Laterality")			DCID (244) Laterality
6	>	HAS PROPERTIES	CODE	EV (121404, DCM, "Selection Status")			
7	>	INFERRED FROM	CODE	DCID (228) Equation or Table			
8	>>	HAS PROPERTIES	NUM				



A.2. TID 1008 Subject Context, Fetus

NO	NL	Relation	with	Value	Concept Name	Used	in	Condition	Value Set Constraint
		Parent		Type		MODALITY			



9 > CONTAIN
S



M7 Series Diagnostic Ultrasound System

21	>>	CONTAINS	INCLUDE	DTID (5025) OB-GYN Fetal Vascular Measurement Group			\$AnatomyGroup = DCID (12141) Fetal Vasculature
22	>	CONTAINS	CONTAINER	EV (121070, DCM, "Findings")			
23	>>	HAS CONCEPT MOD	CODE	EV (G-C0E3, SRT, "Finding Site")			EV (T-D6007, SRT, "Pelvic Vascular Structure")
24	>>	CONTAINS	INCLUDE	DTID (5026) OB-GYN Pelvic Vascular Measurement Group			\$AnatomyGroup = DCID (12140) Pelvic Vasculature Anatomical Location
25	>	CONTAINS	INCLUDE	DTID (SELFTMP-1)			
26	>	CONTAINS	TEXT	(20121120,MRUS, "self-defined-measurementfile")			

A.4. TID (SELFTMP-1) Fetal Cardiac Measurement Group

This is a private template referenced by TID (5000).

NO	NL	Relation with Parent	Value Type	Concept Name	Used in MODALITY	Condition	Value Set Constraint
1			CONTAINER	EV(T0001,MRUS,Fetal Cardiac)			
2	>	HAS OBS CONTEXT	INCLUDE	DTID (1008) Subject Context, Fetus			

A.5. TID (SELFTMP-2) Fetal Zscore

This is a private template referenced by TID (5000).

NO	NL	Relation with Parent	Value Type	Concept Name	Used in MODALITY	Condition	Value Set Constraint
1		CONTAINS	INCLUDE	DTID (300) Measurement			
2		CONTAINS	NUM	EV (C12017-1, MRUS, "Z-Score by Femur Length")			calculated by \$MeasType and Femur Length



M7 Series Diagnostic Ultrasound System

3		CONTAINS	NUM	EV (C12017-2, MRUS, "Z-Score by Biparietal Diameter")			calculated by \$MeasType and Biparietal Diameter
4		CONTAINS	NUM	EV (C12017-3, MRUS, "Z-Score by Clinical Gestational Age")			calculated by \$MeasType and Clinical Gestational Age

A.6. TID (1001) OBSERVATION CONTEXT

This template specifies attributes of observation context that may be defined, extended or replaced at any location in the SR tree.

NO	NL	Relation with Parent	Value Type	Concept Name	Used in MODALITY	Condition	Value Set Constraint
1	>	HAS OBS CONTEXT	CODE	EV (121005,DCM, "Observer Type")			(121006,DCM, "Person")
2	>	HAS OBS CONTEXT	PNAME	EV (121008,DCM, "Person Observer Name")			Operator from Info
3	>	HAS OBS CONTEXT	TEXT	EV (121009,DCM, " Person Observer's Organization Name")			Institution Name (0008,0080) of the General Equipment Module
4	>	HAS OBS CONTEXT	CODE	EV (121010,DCM, " Person Observer's Role in the Organization")			(121093, DCM, "Sonographer")
5	>	HAS OBS CONTEXT	CODE	EV (121024, DCM, "Subject Class")			(121025, DCM, "Patient")
6	>	HAS OBS CONTEXT	PNAME	EV (121029,DCM, "Subject Name")			value of Patient's Name (0010,0010) in Patient Module
7	>	HAS OBS CONTEXT	DATE	EV (121031,DCM, "Subject Birth Date")	*		value of Patient's Birth Date (0010,0030) in Patient Module
8	>	HAS OBS CONTEXT	CODE	EV (121032,DCM, "Subject Sex")	*		value equivalent to Patient's Sex (0010,0040) in Patient Module



M7 Series Diagnostic Ultrasound System

9	>	HAS OBS CONTEXT	NUM	EV (121033,DCM, "Subject Age")	*		value of Patient's Age (0010,1010) in Patient Study Module
---	---	--------------------	-----	-----------------------------------	---	--	---

A.7. TID (5001) OB-GYN Patient Characteristics

NO	NL	Relation with Parent	Value Type	Concept Name	Used in MODALITY	Condition	Value Set Constraint
1			CONTAINER	EV (121118, DCM, "Patient Characteristics")			
2	>	CONTAINS	TEXT	EV (121106, DCM, "Comment")			
3	>	CONTAINS	NUM	EV (8302-2, LN, "Patient Height")			
4	>	CONTAINS	NUM	EV (29463-7, LN, "Patient Weight")			
5	>	CONTAINS	NUM	EV (11996-6, LN, "Gravida")			from info
6	>	CONTAINS	NUM	EV (11977-6, LN, "Para")			from info
7	>	CONTAINS	NUM	EV (11612-9, LN, "Aborta")			from info
8	>	CONTAINS	NUM	EV (33065-4, LN, "Ectopic Pregnancies")			from info(Ectopic)

A.8. TID (5002) OB-GYN Procedure Summary

NO	NL	Relation with Parent	Value Type	Concept Name	Used in MODALITY	Condition	Value Set Constraint
1			CONTAINER	DT (121111, DCM, "Summary")			
2	>	CONTAINS	DATE	(11778-8, LN, "EDD")			from info
3	>	CONTAINS	DATE	(11779-6, LN, "EDD from LMP")			from info
4	>	CONTAINS	DATE	(11781-2, LN, "EDD from average ultrasound age")			
5	>	CONTAINS	DATE	(11780-4, LN, "EDD from ovulation date")			from info



M7 Series Diagnostic Ultrasound System

6	>	CONTAINS	DATE	(I1955-2, LN, "LMP")			from info
7	>	CONTAINS	DATE	(33066-2, LN, "Estimated LMP by EDD")			from info
8	>	CONTAINS	DATE	(11976-8, LN, "Ovulation date")			from info
9	>	CONTAINS	DATE	(I12003-01, MRUS, "IVF")			from info
10	>	CONTAINS	DATE	(C12003-01, MRUS, "EDD from IVF")			from info
11	>	CONTAINS	DATE	(I12003-02, MRUS, "PRV")			from info
12	>	CONTAINS	DATE	(C12003-02, MRUS, "EDD from PRV")			from info
13	>	CONTAINS	INCLUDE	DTID (300) Measurement			\$Measurement = (11886-9, LN, "Gestational Age by ovulation date")
14	>	CONTAINS	TEXT	EV (I21106, DCM, "Comment")			from info
15	>	CONTAINS	TEXT	(I12101-01, MRUS, "Primary Indications")			from info
16	>	CONTAINS	TEXT	(I12101-02, MRUS, "Secondary Indications")			from info
17	>	CONTAINS	TEXT	(I12101-03, MRUS, "CPT4 Code")			from info
18	>	CONTAINS	TEXT	(I12101-04, MRUS, "CPT4 Description")			from info
19	>	CONTAINS	TEXT	EV (I21106, DCM, "Comment")			report interface Comments
20	>	CONTAINS	TEXT	(I12101-05, MRUS, "Prompt")			report interface Prompt
21	>	CONTAINS	TEXT	(I21071, DCM, "Findings")			report interface Findings
22	>>		INCLUDE	DTID (320) Image or Spatial Coordinates			
23	>	CONTAINS	INCLUDE	BTID (5003) OB-GYN Fetus Summary			



A.9. TID (5003) OB-GYN Fetus Summary

	NL	Rel with Parent	VT	Concept Name	Used in MODALITY	Condition	Value Set Constraint
1			CONTAINER	DT (125008, DCM, "Fetus Summary")			
2	>	HAS OBS CONTEXT	TEXT	EV (11951-1, LN, "Fetus ID")			
3	>	HAS OBS CONTEXT	NUM	EV (11878-6, LN, "Number of Fetuses")			
4	>	CONTAINS	INCLUDE	DTID (300) Measurement			\$Measurement = (11859, LN, "Gestational Age")
5	>	CONTAINS	INCLUDE	DTID (300) Measurement	NT 'S-88811)		\$Measurement = (11885, LN, "Composite Ultrasound")



M7 Series Diagnostic Ultrasound System

NL R36 Tm 130.68 755.36 Tm



M7 Series Diagnostic Ultrasound System

	NL	Rel with Parent	VT	Concept Name	Used in MODALITY	Condition	Value Set Constraint
3	>	CONTAINS	TEXT	(FG7455-01,MRUS,"Gender")			
4	>	CONTAINS	TEXT	(FG7160-01,MRUS,"3 Vessel Cord")			
5	>	CONTAINS	TEXT	(T-D1200,SNM3,"Face")			
6	>	CONTAINS	TEXT	(FG4-01,MRUS,"Nose Lips")			
7	>	CONTAINS	TEXT	(FG12011-01,MRUS,"Cord insertion")			
8	>	CONTAINS	TEXT	(FG4031-01,MRUS,"LUS")			
9	>	CONTAINS	TEXT	(T-57000,SNM3,"Stomach")			
10	>	CONTAINS	CONTAINER	(T-71000,SRT,"Kidney")			
11	>>	CONTAINS	TEXT	(G-A100,SNM3,"Left")			
12	>>	CONTAINS	TEXT	(G-A101,SNM3,"Right")			
13	>	CONTAINS	TEXT	(T-74000,SRT,"Bladder")			
14	>	CONTAINS	TEXT	(T-63000,SRT,"Gall bladder")			
15	>	CONTAINS	TEXT	(T-62000,SRT,"Liver")			
16	>	CONTAINS	TEXT	(T-D3400,SRT," Diaphragm ")			
17	>	CONTAINS	TEXT	(FG4031-02,MRUS,"Fetal Bowel")			

A.11. TID (FINDING_2) Fetus Limbs

This is a private template referenced by TID (5003).

	N L	Rel with Parent	VT	Concept Name	Used in MODALITY	Condi on	Value Set Constrai nt
1		CONTAINS	CONTAIN ER	(FG4031-03,MRUS,"Fetus Limbs")			
2	>	CONTAINS	TEXT	(FG4031-04,MRUS,"Upper Extremities")			
3	>	CONTAINS	TEXT	(FG4031-05,MRUS,"Lower Extremities")			

A.12. TID (FINDING_3) Fetal Cardiology

This is a private template referenced by TID (5003).

	N L	Rel with Parent	VT	Concept Name	Used in MODALITY	Condi on	Value Set Constrai nt
1		CONTAINS	CONTAIN ER	(FG4031-06,MRUS,"Fetal Cardiology")			
2	>	CONTAINS	TEXT	(FG12239-01,MRUS,"Cardiac Activity")			
3	>	CONTAINS	TEXT	(FG4031-07,MRUS,"4C HEART")			
4	>	CONTAINS	TEXT	(T-42000,SNM3,"Aorta")			
5	>	CONTAINS	TEXT	(T-44000,SNM3,Pulmonary Artery)			
6	>	CONTAINS	TEXT	(FG3010-01,MRUS,"ARCH")			
7	>	CONTAINS	TEXT	(FG3010-03,MRUS," Decrease ARCH ")			

A.13. TID (FINDING_4) Fetal Brain

This is a private template referenced by TID (5003).

	N L	Rel with Parent	VT	Concept Name	Used in MODALITY	Condi on	Value Set Constrai nt
1		CONTAINS	CONTAIN ER	(FG4030-01,MRUS,"Fetal Brain")			



M7 Series Diagnostic Ultrasound System

N Rel with

L Parent



M7 Series Diagnostic Ultrasound System

	N L	Rel with Parent	VT	Concept Name	Used in MODALITY	Conditio n	Value Set Constraint
4	>	CONTAINS	TEXT	(FG12011-03,MRUS,"Placental Grade")			

A.16. TID (FINDING_7) Maternal Description

This is a private template referenced by TID (5003).

	N L	Rel with Parent	VT	Concept Name	Used in MODALITY	Conditio n	Value Set Constraint
1		CONTAINS	CONTAINER	(FG6088-01,MRUS,"Maternal Description")			
2	>	CONTAINS	CONTAINER	(FG12011-03,MRUS,"Adnexa")			
3	>>	CONTAINS	TEXT	(G-A100,SNM3,Right)			
4	>>	CONTAINS	TEXT	(G-A101,SNM3,Left)			
5	>	CONTAINS	CONTAINER	(T-87000,SRT,"Ovary")			
6	>>	CONTAINS	TEXT	(G-A100,SNM3,Right)			
7	>>	CONTAINS	TEXT	(G-A101,SNM3,Left)			
8	>	CONTAINS	CONTAINER	(T-71000,SRT,Kidney)			
9	>>	CONTAINS	TEXT	(G-A100,SNM3,Right)			
10	>>	CONTAINS	TEXT	(G-A101,SNM3,Left)			
11	>	CONTAINS	TEXT	(T-83200,SRT,Cervix)			

A.17. TID (5004)Fetal Biometry Ratio Section

	N L	Rel with Parent	VT	Concept Name	Used in MODALITY	Condition	Value Set Constraint
1			CONTAINER	DT (125001, DCM, "Fetal Biometry Ratios")			
2	>	HAS OBS CONTEXT	INCLUDE	EV (11951-1, LN, "Fetus ID")			



M7 Series Diagnostic Ultrasound System

	NL	Rel with Parent	VT	Concept Name	Used in MODALITY	Condition	Value Set Constraint
3	>	HAS OBS CONTEXT	NUM	EV (11878-6, LN, "Number of Fetuses")			
4	>	CONTAINS	NUM	(11947-9, LN, "HC/AC")			
5	>	CONTAINS	NUM	(11871-1, LN, "FL/AC")			
6	>	CONTAINS	NUM	(11872-9, LN, "FL/BPD")			
7	>	CONTAINS	NUM	(11823-2, LN, "Cephalic Index")			
8	>	CONTAINS	NUM	(11873-7, LN, "FL/HC")			
9	>	CONTAINS	NUM	(C12004-01, MRUS, HrtC/TC)			
10	>	CONTAINS	NUM	(C12004-02, MRUS, "TCD/AC")			
11	>	CONTAINS	NUM	(C12004-03, MRUS, LVW/HW)			
12	>	CONTAINS	NUM	(C12004-04, MRUS, "Cephalic Index by HC")			

A.18. TID (5005) Fetal Biometry Section

	NL	Rel with Parent	VT	Concept Name	Used in MODALITY	Condition	Value Set Constraint
1			CONTAINER	DT (125002, DCM, "Fetal Biometry")			
2	>	HAS OBS CONTEXT	TEXT	EV (11951-1, LN, "Fetus ID")			
3	>	HAS OBS CONTEXT	NUM	EV (11878-6, LN, "Number of Fetuses")			
4	>	CONTAINS	INCLUDE	DTID (5008) Fetal Biometry Group			\$BiometryType = MemberOf {DCID (12005) Fetal Biometry

							Measurements}
--	--	--	--	--	--	--	---------------

A.19. TID (5006) Fetal Long Bones Section

	NL	Rel with Parent	VT	Concept Name	Used in MODALITY	Condition	Value Set Constraint
1			CONTAINER	DT (125003, DCM, "Fetal Long Bones")			
2	>	HAS OBS CONTEXT	TEXT	EV (11951-1, LN, "Fetus ID")			
3	>	HAS OBS CONTEXT	NUM	EV (11878-6, LN, "Number of Fetuses")			
4	>	CONTAINS	INCLUDE	DTID (5008) Fetal Biometry Group			\$BiometryType = MemberOf {DCID (12006) Fetal Long Bones Biometry Measurements}

A.20. TID (5007) Fetal Cranium Section

	NL	Rel with Parent	VT	Concept Name	Used in MODALITY	Condition	Value Set Constraint
1			CONTAINER	DT (125004, DCM, "Fetal Cranium")			
2	>	HAS OBS CONTEXT	TEXT	EV (11951-1, LN, "Fetus ID")			
3	>	HAS OBS CONTEXT	NUM	EV (11878-6, LN, "Number of Fetuses")			
4	>	CONTAINS	INCLUDE	DTID (5008) Fetal Biometry Group			\$BiometryType = MemberOf {DCID (12007) Fetal Cranium}

A.21. TID (5008) Fetal Biometry Group



M7 Series Diagnostic Ultrasound System

2	>	HAS OBS CONTEXT	INCLUDE	EV (11951-1, LN, "Fetus ID")			
3	>	HAS OBS CONTEXT	NUM	EV (11878-6, LN, "Number of Fetuses")			
4	>	CONTAINS	NUM	EV (11631-9, LN, "Gross Body Movement")			Units = DT ("{0:2}", UCUM, "range 0:2")
5	>>	HAS PROPERTIES	TEXT	(121106, DCM, "Comment")			
6	>	CONTAINS	NUM	EV (11632-7, LN, "Fetal Breathing")			Units = DT ("{0:2}", UCUM, "range 0:2")
7	>>	HAS PROPERTIES	TEXT	(121106, DCM, "Comment")			
8	>	CONTAINS	NUM	EV (11635-0, LN, "Fetal Tone")			Units = DT ("{0:2}", UCUM, "range 0:2")
9	>>	HAS PROPERTIES	TEXT	(121106, DCM, "Comment")			
10	>	CONTAINS	NUM	EV (11635-5, LN, "Fetal Heart Reactivity")			Units = DT ("{0:2}", UCUM, "range 0:2")
11	>>	HAS PROPERTIES	TEXT	(121106, DCM, "Comment")			
12	>	CONTAINS	NUM	EV (11630-1, LN, "Amniotic Fluid Volume")			Units = DT ("{0:2}", UCUM, "range 0:2")
13	>>	HAS PROPERTIES	TEXT	(121106, DCM, "Comment")			
14	>	CONTAINS	NUM	DT (11634-3, LN, "Biophysical Profile Sum Score")			
15	>>	HAS PROPERTIES	TEXT	(121106, DCM, "Comment")			

A.23. TID (5010) Amniotic Sac Section

	N L	Rel with Parent	VT	Concept Name	Used in MODALITY	Condition	Value Set Constraint
1			CONTAINER	DT (121070, DCM, "Findings")	✓		
2	>	HAS CONCEPT MOD	CODE	EV (G-COE3, SRT, "Finding Site")	✓		DT (T-F1300, SRT, "Amniotic Sac")
3	>	CONTAINS	INCLUDE	DTID (300) Measurement	✓		\$Measurement = DT (11627-7, LN, "Amniotic Fluid Index")
4	>	CONTAINS	INCLUDE	DTID (300) Measurement	✓		\$Measurement = (11624-4, LN, "First Quadrant Diameter"),
5	>	CONTAINS	INCLUDE	DTID (300) Measurement	✓		\$Measurement = (11626-9, LN, "Second Quadrant Diameter")
6	>	CONTAINS	INCLUDE	DTID (300) Measurement	✓		\$Measurement = (11625-1, LN, "Third Quadrant Diameter")
7	>	CONTAINS	INCLUDE	DTID (300) Measurement	✓		\$Measurement = (11623-6, LN, "Fourth Quadrant Diameter")
8	>	CONTAINS	INCLUDE	DTID (300) Measurement	✓		\$Measurement = (M12008-01,MRU S, "Amniotic Fluid")

A.24. TID (5011) Early Gestation Section

	NL	Relation	Value Type	Concept	Used in	Condition	Value Set
--	----	----------	------------	---------	---------	-----------	-----------

		with Parent		Name	MODALITY		Constraint
1			CONTAINER	DT (125009, DCM, "Early Gestation")			
2	>	HAS OBS CONTEXT	TEXT	EV (11951-1,LN, "Fetus ID")			
3	>	HAS OBS CONTEXT	NUM	EV (11878-6,LN, "Number of Fetuses")			
4	>	CONTAINS	INCLUDE	DTID (5008) Fetal Biometry Group			\$BiometryType= Member of {DCID (12009) Early Gestation Biometry Measurements}

A.25. TID (5012) Ovaries Section

	NL	Relation with Parent	Value Type	Concept Name	Used in MODALITY	Condition	Value Set Constraint
1			CONTAINER	DT (121070, DCM, "Findings")			
2	>	HAS CONCEPT MOD	CODE	EV (G-COE3, SRT, "Finding Site")			DT (T-87000, SRT, "Ovary")
3	>	CONTAINS	INCLUDE	EV (T-87000, SRT, "Ovary")			\$Measurement = EV (T-87000, SRT, "Ovary")
4	>>	CONTAINS	INCLUDE	DTID (300) Measurement			\$Measurement = EV (11829-9,LN, "Left Ovary



M7 Series Diagnostic Ultrasound System

							Width")
5	>>	CONTAINS	INCLUDE	DTID (300) Measurement			\$Measurement = EV (11840-6, LN, "Left Ovary Length")
6	>>	CONTAINS	INCLUDE	DTID (300) Measurement			\$Measurement = EV (11857-0, LN, "Left Ovary Height")
7	>>	CONTAINS	INCLUDE	DTID (300) Measurement			\$Measurement = EV (12164-0, LN, "Left Ovary Volume")
8	>	CONTAINS	INCLUDE	EV (T-87000, SRT, "Ovary")			\$GroupName = EV (T-87000, SRT, "Ovary")
9	>>	CONTAINS	INCLUDE	DTID (300) Measurement			\$Measurement = EV (11830-7, LN, "Right Ovary Width")
10	>>	CONTAINS	INCLUDE	DTID (300) Measurement			\$Measurement = EV (11841-4, LN, "Right Ovary Length")
11	>>	CONTAINS	INCLUDE	DTID (300) Measurement			\$Measurement = EV (11858-8, LN, "Right Ovary Height")
12	>>	CONTAINS	INCLUDE	DTID (300) Measurement			\$Measurement = EV (12165-7, LN, "Right Ovary Volume")

A.26. TID (5013) Follicles Section

	NL	Relation with Parent	Value Type	Concept Name	Used in MODALITY	Condition	Value Set Constraint
1			CONTAINER	DT (121070, DCM, "Findings")			
2	>	HAS CONCEPT MOD	CODE	EV (G-C0E3, SRT, "Finding Site")			DT (T-87600, SRT, "Ovarian Follicle")



M7 Series Diagnostic Ultrasound System

3	>	HAS CONCEPT MOD	CODE	EV (G-C171, SRT, "Laterality")			\$Laterality
4	>	CONTAINS	NUM	EV (11879-4, LN, "Number of follicles in left ovary") OR EV (11880-2, LN, "Number of follicles in right ovary") Number of follicles in the ovary.			
5	>	CONTAINS	INCLUDE	DTID (5014) Follicle Measurement Group			

A.27. TID (5014) Follicle Measurement Group

	NL	Relation with Parent	Value Type	Concept Name	Used in MODALITY	Condition	Value Set Constraint
1			CONTAINER	EV (125007, DCM, "Measurement Group")			
2	>	HAS OBS CONTEXT	TEXT	EV (12510, DCM, "Identifier")			Unique among all groups of same laterality
3	>	CONTAINS	INCLUDE	DTID (300) Measurement			\$Measurement = EV (G-D705, SRT, "Volume")
4	>	CONTAINS	INCLUDE	DTID (300) Measurement			\$Measurement = EV (M11793-02, MRUS, "Follicle Length")



M7 Series Diagnostic Ultrasound System

5	>	CONTAINS	INCLUDE	DTID (300) Measurement			\$Measurement = EV (M11793-01, LN, "Follicle Width")
6	>	CONTAINS	INCLUDE	DTID (300) Measurement			\$Measurement = EV (M11794-01, MRUS, "Follicle Thickness")
7	>	CONTAINS	INCLUDE	DTID (300) Measurement			\$Measurement = EV (11793-7, LN, "Follicle Diameter")

A.28. TID (5015) Pelvis And Uterus Section

N L	Relation with Parent	Value Type	Concept Name	Used in MODALITY	Condition	Value Set Constraint
1		CONTAINER	DT (125011, DCM, "Pelvis and Uterus")			
2	>	CONTAINS	CONTAINER	\$GroupName		\$GroupName = EV (T-83000, SRT, "Uterus")
3	>>	CONTAINS	INCLUDE	DTID (300) Measurement		\$Measurement = \$Width \$Width = EV (11865-3, LN, " Uterus Width")
4	>>	CONTAINS	INCLUDE	DTID (300) Measurement		\$Measurement = \$Length \$Length = EV (11842-2, LN, "Uterus Length")
5	>>	CONTAINS	INCLUDE	DTID (300) Measurement		\$Measurement = \$Height \$Height = EV (11859-6, LN, "Uterus Height")
6	>>	CONTAINS	INCLUDE	DTID (300) Measurement		\$Measurement = \$Volume \$Volume = EV (33192-6, LN, "Uterus Volume")
7	>	CONTAINS	INCLUDE	DTID (300) Measurement		\$Measurement = EV(LN,11961-0,Cervix Length)
8	>	CONTAINS	INCLUDE	DTID (300) Measurement		\$Measurement = EV(LN,12145-9,Endometriu m Thickness)



M7 Series Diagnostic Ultrasound System

9	>	CONTAINS	INCLUDE	DTID (300) Measurement			\$Measurement = (MRUS,M12011-01,Cervix Height)
10	>	CONTAINS	INCLUDE	DTID (300) Measurement			\$Measurement = (MRUS,M12011-02,Cervix Width)
11	>	CONTAINS	INCLUDE	DTID (300) Measurement			\$Measurement = (MRUS,C12011-03,Uterus Body)
12	>	CONTAINS	INCLUDE	DTID (300) Measurement			\$Measurement = (MRUS,C12011-04,UT_L/C X_L)
13	>	CONTAINS	INCLUDE	DTID (300) Measurement			\$Measurement = (MRUS,M12011-03,Matrix Kindney Length)

A.29. TID (5025) OB-GYN Fetus Vascular Ultrasound Measurement Group

	NL	Rel with Parent	VT	Concept Name	Used in MODALITY	Condition	Value Set Constraint
1			CONTAINER	\$AnatomyGroup			
2	>	HAS OBS CONTEXT	TEXT	EV (11951-1,LN, "Fetus ID")			
3	>	HAS OBS CONTEXT	NUM	EV (11878-6,LN, "Number of Fetuses")			
4	>	HAS CONCEPT MOD	CODE	EV (G-C171, SRT "Laterality")			DCID (244) Laterality
5	>	CONTAINS	INCLUDE	DTID (300) Measurement			\$MeasType = DCID (12119) Vascular Ultrasound Property \$Derivation = DCID (3627) Measurement Type



**A.30. TID (5026) OB-GYN Pelvic Vascular Ultrasound
Measurement Group**

	N L	Rel with Parent	VT	Concept Name	Used in MODALITY	Condition	Value Set Constraint
1			CONTAINER	\$AnatomyGroup			
2	>	HAS CONCEPT MOD	CODE	EV (G-C171, SRT, “Laterality”)			DCID (244) Laterality
3	>	HAS CONCEPT MOD	TEXT	(112050, DCM, “Anatomic Identifier”)			
4	>	CONTAINS	INCLUDE	DTID (300) Measurement			\$MeasType = DCID (12119) Vascular Ultrasound Property \$Derivation = DCID (3627) Measurement Type

A.31. CID (228) Equation or Table

CSD CV V VCSsD- Me).30491()8.02987 C00000

SRT	R-002E1	Best value
SRT	R-00317	Mean
SRT	R-00319	Median
SRT	R-0032E	Mode
SRT	R-00355	Point source measurement
SRT	R-00353	Peak to peak
SRT	R-41D27	Visual estimation
SRT	R-10260	Estimated
SRT	R-41D2D	Calculated
SRT	R-41D41	Measured

A.34. CID (12005) Fetal Biometry Measurements

CSD	CV	Code Meaning
LN	11979-2	Abdominal Circumference
LN	11818-2	Anterior-Posterior Abdominal Diameter
LN	11819-0	Anterior-Posterior Trunk Diameter
LN	11820-8	Biparietal Diameter
LN	11860-4	Cisterna Magna
LN	11963-6	Femur Length
LN	11965-1	Foot length
LN	11984-2	Head Circumference
LN	11851-3	Occipital-Frontal Diameter
LN	11988-3	Thoracic Circumference
LN	33068-8	Thoracic Area
LN	11862-0	Transverse Abdominal Diameter
LN	11863-8	Trans Cerebellar Diameter
LN	11864-6	Transverse Thoracic Diameter
LN	33191-8	APAD * TAD
MRUS	M12005-05	Fetal Kidney length
MRUS	M12005-01	Thoracic Diameter
MRUS	M12005-02	Heart Circumference
MRUS	M12011-01	Placental Thickness
MRUS	M12005-03	Anterior-Posterior Abdominal Diameter by AC
MRUS	M12005-04	Transverse Abdominal Diameter by AC

A.35. CID (12006) Fetal Long Bones Measurements

CSD	CV	Code Meaning
LN	11966-9	Humerus length
LN	11967-7	Radius length
LN	11969-3	Ulna length
LN	11968-5	Tibia length
LN	11964-4	Fibula length
LN	11962-8	Clavicle length
LN	11963-6	Femur Length

A.36. CID (12007) Fetal Cranium

CSD	CV	Code Meaning
LN	12171-5	Lateral Ventricular width
LN	11860-4	Cisterna Magna length
LN	12146-7	Nuchal Fold thickness
LN	33070-4	Inner Orbital Diameter
LN	11629-3	Outer Orbital Diameter
LN	11863-8	Trans Cerebellar Diameter
LN	33069-6	Nuchal Translucency
LN	12170-7	Width of Hemisphere
MRUS	M12007-01	Ear Length
MRUS	M12007-02	Middle Phalanx Length
MRUS	M12007-03	Orbit
MRUS	M12007-04	OFDHC
MRUS	C12007-01	HCc

A.37. CID (12009) Early Gestation Biometry Measurements

CSD	CV	Code Meaning
LN	11957-8	Crown Rump Length
LN	11850-5	Gestational Sac Diameter
LN	33071-2	Spine Length

LN	11816-6	Yolk Sac length
LN	33069-6	Nuchal Translucency
MRUS	C12009-01	Mean Gestational Sac Diameter
MRUS	M12009-01	Gestational Sac Diameter1
MRUS	M12009-02	Gestational Sac Diameter2
MRUS	M12009-03	Gestational Sac Diameter3

A.38. CID (12013) Gestational Age Equations and Tables

CSD	CV	Code Meaning
LN	11885-1	Gestational Age by LMP
LN	11892-7	AC, Hadlock 1984
LN	11893-5	AC, Jeanty 1984
LN	33148-8	AC by GA, Merz 1988
LN	11902-4	BPD, Hadlock 1984
LN	11903-2	BPD, Hansmann 1985
LN	11905-7	BPD, Jeanty 1984
LN	33082-9	BPD, Osaka 1989
LN	33083-7	BPD, Rempen 1991
LN	11906-5	BPD, Kurtz 1980
LN	33088-6	Clavical length, Yarkoni 1985
LN	11910-7	CRL, Hadlock 1992
LN	11911-5	CRL, Hansmann 1985
LN	11917-2	CRL, Jeanty 1984
LN	11913-1	CRL, Nelson 1981
LN	33094-4	CRL, Rempen 1991
LN	11914-9	CRL, Robinson 1975
LN	33138-9	Fetal Trunk Cross-Sectional Area, Osaka 1989
LN	11920-6	FL, Hadlock 1984
LN	11922-2	FL, Hohler 1982
LN	11923-0	FL, Jeanty 1984
LN	11929-7	GS, Rempen 1991
LN	11932-1	HC, Hadlock 1984
LN	33112-4	HC, Hansmann 1985
LN	11934-7	HC, Jeanty 1984
LN	33111-6	HC derived, Chitty 1997



M7 Series Diagnostic Ultrasound System

CSD	CV	Code Meaning
LN	11936-2	Humerus, Jeanty 1984
LN	33544-8	OFD, Hansmann 1985
LN	33134-8	TCD, Hill 1990
MRUS	F12013-01	AC, ASUM 2001
MRUS	F12013-02	AC,Nicolaides 1994
MRUS	F12013-03	BPD, ASUM 2001
MRUS	F12013-04	BPD, Merz 1991
MRUS	F12013-05	BPD, Tokyo 1989
MRUS	F12013-06	BPD-oo, Chitty 1994
MRUS	F12013-07	CRL, ASUM 2001
MRUS	F12013-08	CRL, Tokyo 1989
MRUS	F12013-24	EFW, Tokyo 1989
MRUS	F12013-09	FL, ASUM 2001
MRUS	F12013-10	FL, Chitty 1997
MRUS	F12013-12	FL, Merz 1991
MRUS	F12013-13	FL, Tokyo 1989
MRUS	F12013-14	FL,Warda,1985
MRUS	F12013-15	GS, Tokyo 1986
MRUS	F12013-17	HC derived, Chitty 1994
MRUS	F12013-16	HC, ASUM 2001
MRUS	F12013-18	HC,Nicolaides 1994
MRUS	F12013-19	Humerus Length, ASUM 2001
MRUS	F12013-20	OFD, ASUM 2001
MRUS	F12013-21	OFD,Nicolaides 1994
MRUS	F12013-22	OOD, Jeanty 1984
MRUS	F12013-23	TCD,Nicolaides 1994
MRUS	F12013-24	THD,Hansmann 1985
MRUS	F12013-25	GS, Hansmann 1985
MRUS	F12013-26	FL, Hansmann 1995
MRUS	F12013-43	EFW, Hadlock 1991
MRUS	F12013-44	Mean Sac Diameter Daya 1991
MRUS	F12013-45	GS,China 1997
MRUS	F12013-46	CRL,China 1997
MRUS	F12013-47	BPD,China 1997
MRUS	F12013-48	BPD,Nicolaides 1994

CSD	CV	Code Meaning
MRUS	F12013-49	FL,China 1997
MRUS	F12013-50	FL,Nicolaides 1994
MRUS	F12013-52	AC, Hansmann1986
MRUS	F12013-53	AC, CFEF Crequat2000
MRUS	F12013-54	AC,Chitty (plotted) 1994
MRUS	F12013-55	CRL, Robinson hp BMUS 1975
MRUS	F12015-22	FL,Osaka 1989

A.39. CID (12014) Fetal Body Weight

CSD	CV	Code Meaning
LN	11739-0	EFW by AC and BPD, Shepard 1982
LN	11756-4	EFW by AC, Campbell 1975
LN	33144-7	EFW by BPD, APTD, TTD, FL, Tokyo 1987
LN	11735-8	EFW by AC, BPD, FL, Hadlock 1985
LN	11732-5	EFW by AC, BPD, FL, HC, Hadlock 1985
LN	11751-5	EFW by AC, FL, Hadlock 1985
LN	11746-5	EFW by AC, FL, HC, Hadlock 1985
LN	11884-4	Average Ultrasound Age
MRUS	F12013-27	CUA by BPD, Hadlock 1984
MRUS	F12013-28	CUA by AC, Hadlock 1984
MRUS	F12013-29	CUA by HC, Hadlock 1984
MRUS	F12013-30	CUA by FL, Hadlock 1984
MRUS	F12013-31	CUA by BPD, HC, Hadlock 1984
MRUS	F12013-32	CUA by BPD, AC, Hadlock 1984
MRUS	F12013-33	CUA by BPD, FL, Hadlock 1984
MRUS	F12013-34	CUA by HC, AC, Hadlock 1984
MRUS	F12013-35	CUA by HC, FL, Hadlock 1984
MRUS	F12013-36	CUA by AC, FL, Hadlock 1984
MRUS	F12013-37	CUA by BPD, HC, AC, Hadlock 1984
MRUS	F12013-38	CUA by BPD, HC, FL, Hadlock 1984
MRUS	F12013-39	CUA by BPD, AC, FL, Hadlock 1984
MRUS	F12013-40	CUA by HC, AC, FL, Hadlock 1984
MRUS	F12013-41	CUA by BPD, HC, AC, FL, Hadlock 1984

CSD	CV	Code Meaning
MRUS	F12014-01	EFW by AC,BPD,Merz 1991
MRUS	F12014-02	EFW by AC,Merz 1991
MRUS	F12014-03	EFW by BPD, TTD, Hansmann 1995
MRUS	F12014-04	EFW by BPD, FTA, FL, Osaka 1983
MRUS	F12014-05	EFW by AC,HC,FL,Schild 2004
MRUS	F12014-06	EFW by BPD,FL,MAD,Persson 1996

A.40. CID (12015) Fetal Growth Equations and Tables

CSD	CV	Code Meaning
LN	33146-2	AC by GA, Hadlock 1984
LN	33546-3	AC (derived) by GA, Chitty 1994
LN	33198-3	BPD by GA, Hadlock 1984
LN	33152-0	outer-outer by GA, Chitty 1994
LN	33155-3	BPD by GA, Rempen 1991
LN	33160-3	CRL by GA, Rempen 1991
LN	33166-0	FL by GA, Hadlock 1984
LN	33167-8	FL by GA, Chitty 1994
LN	33171-0	GS by GA, Rempen 1991
LN	33173-6	HC by GA, Hadlock 1984
LN	33174-4	HC derived by GA, Chitty 1994
LN	33181-9	TCD by GA Goldstein 1987
LN	33097-7	Fibula, Jeanty 1983
LN	33126-4	Radius, Jeanty 1983
MRUS	F12015-01	AC by GA, ASUM 2001
MRUS	F12015-02	AC by GA, Merz 1991
MRUS	F12015-03	AC, Jeanty 1984
MRUS	F12015-04	APAD,Merz 1991
MRUS	F12015-05	BPD by GA, ASUM 2001
MRUS	F12015-06	BPD, Hansmann 1985
MRUS	F12015-07	BPD by GA, Merz 1988
MRUS	F12015-08	BPD,Kurtz,1980
MRUS	F12015-09	BPD,Sabbagha 1978
MRUS	F12015-10	BPD, Tokyo 1989
MRUS	F12015-12	Clavical length,Yarkoni 1985

CSD	CV	Code Meaning
MRUS	F12015-13	CRL by GA ASUM 2001
MRUS	F12015-14	CRL, Hansmann 1985
MRUS	F12015-15	CRL, Robinson 1975
MRUS	F12015-16	CRL, Tokyo 1989
MRUS	F12015-17	EFW by GA, Hadlock 1984
MRUS	F12015-18	FL by GA, ASUM 2001
MRUS	F12015-19	FL, Hansmann 1995
MRUS	F12015-20	FL by GA, Merz 1991
MRUS	F12015-21	FL, O'Brien, 1981
MRUS	F12015-22	FL, Osaka 1989
MRUS	F12015-23	FL, Tokyo, 1989
MRUS	F12015-24	FL, Warda, 1985
MRUS	F12015-25	FIB, Merz, 1991
MRUS	F12015-26	FTA, Osaka 1989
MRUS	F12015-27	HC by GA, ASUM 2001
MRUS	F12015-28	HC, Hansmann 1985
MRUS	F12015-29	HC by GA, Merz 1991
MRUS	F12015-30	Humerus Length by GA, ASUM 2001
MRUS	F12015-31	OFD by GA, ASUM 2001
MRUS	F12015-32	OFD, Hansmann 1985
MRUS	F12015-33	OFD, Merz 1991
MRUS	F12015-34	OFD, Nicolaides 1994
MRUS	F12015-35	RAD, Merz 1991
MRUS	F12015-36	TAD, Merz 1991
MRUS	F12015-37	TCD, Hill 1990
MRUS	F12015-38	THD, Hansmann 1985
MRUS	F12015-39	Tibia, Merz 1991
MRUS	F12015-40	Ulna, Merz 1991
MRUS	F12015-41	EFW by GA, Hansmann 1995

A.41. CID (12119) Vascular Ultrasound Property

CSD	CV	Code Meaning
INCLUDE	CID 12120	Blood Velocity Measurements
INCLUDE	CID 12121	Vascular Indices and Ratios

CSD	CV	Code Meaning
INCLUDE	CID 12122	Other Vascular Properties

A.42. CID (12120) Blood Velocity Measurements

CSD	CV	Code Meaning
LN	11653-3	End Diastolic Velocity
LN	11665-7	Minimum Diastolic Velocity
LN	11726-7	Peak Systolic Velocity
LN	11726-7	Peak Velocity
LN	20352-1	Time averaged mean velocity
LN	11692-1	Time averaged peak velocity

A.43. CID (12121) Vascular Indices and Ratios

CSD	CV	Code Meaning
LN	12008-9	Pulsatility Index
LN	12023-8	Resistivity Index
LN	12144-2	Systolic to Diastolic Velocity Ratio
MRUS	M12119-04	Diastolic to Systolic Velocity Ratio
MRUS	C12121-1	Systolic to Atrial Contraction Velocity Ratio
MRUS	M12120-1	Peak Early Diastolic Velocity
MRUS	C12121-2	Peak velocity index for the vein

A.44. CID (12122) Other Vascular Properties

CSD	CV	Code Meaning
LN	20168-1	Acceleration Time
LN	20217-6	Deceleration Time
SRT	R-1025C	Vessel Intimal Diameter
LN	20247-3	Peak Gradient
LN	20256-4	Mean Gradient
LN	20354-7	Velocity Time Integral
LN	11948-7	Fetal Heart Rate
LN	8867-4	Heart rate
MRUS	M12119-02	Angle
MRUS	M12119-01	Mean Velocity Mean Pressure Gradient

MRUS	M12119-06	Vol Flow(TAMAX)
MRUS	M12119-07	Vol Flow(TAMEAN)

A.45. CID (12140) Pelvic Vasculature Anatomical Location

CSD	CV	Code Meaning
SRT	T-46980	Ovarian Artery
SRT	T-46820	Uterine Artery

A.46. CID (12141) Fetal Vasculature Anatomical Location

CSD	CV	Code Meaning
SRT	T-42000	Aorta
SRT	T-D0765	Descending Aorta
SRT	T-45600	Middle Cerebral Artery
MRUS	V12141-01	Ductus Venosus
SRT	T-F1810	Umbilical Artery
SRT	T-F1820	Umbilical Vein
SRT	T-F1412	Vitelline Artery of Placenta



M7 Series Diagnostic Ultrasound System

MRUS	C12212-01	Aorta Diameter/Main Pulmonary Artery Diameter
MRUS	C12212-03	Aorta Diameter/Main Pulmonary Artery Diameter(Z Score)
MRUS	M12201-01	Left ventricular short-axis diameter at end diastole
MRUS	M12201-08	Left ventricular short-axis diameter at end diastole(Z Score)
MRUS	M12201-02	Left ventricular short-axis diameter at end systole
MRUS	M12201-03	Left ventricular Diameter
MRUS	M12201-09	Left ventricular Diameter(Z Score)
MRUS	M12201-04	interventricular septal thickness
MRUS	M12201-05	Left Ventricular Outflow Tract Diameter
MRUS	M12204-01	Right ventricular short-axis diameter at end diastole
MRUS	M12204-07	Right ventricular short-axis diameter at end diastole(Z Score)
MRUS	M12204-02	Right ventricular short-axis diameter at end systole
MRUS	M12204-03	Right ventricular Diameter
MRUS	M12204-08	Right ventricular Diameter(Z Score)
MRUS	M12204-09	Right ventricular area(Z Score)
MRUS	M12204-04	Right ventricular area
MRUS	M12206-01	Right Atrium Diameter
MRUS	M12204-05	Right Ventricular Outflow Tract Diameter
MRUS	M12205-01	Left Atrium Diameter
MRUS	M12205-02	Left Atrium area
MRUS	M12206-02	Right Atrium area
MRUS	M12240-01	Left ventricular area
MRUS	M12240-02	Left ventricular area(Z Score)
MRUS	M12209-1	Pulmonary Valve Diameter(Z Score)
MRUS	M12215-1	Inferior Vene Cava Diameter(Z Score)
MRUS	M12212-1	Duct Aorta Diameter(Z Score)

A.48. Mapping between Modality measurements and DICOM Concepts.

A.48.1. OB-GYN Measurements

<i>MODALITY Label</i>	<i>DICOM Mapping</i>
FHR	11948-7, LN, Fetal Heart Rate
HC/AC	11947-9, LN, HC/AC
FL/AC	11871-1, LN, FL/AC
FL/BPD	11872-9, LN, FL/BPD
CI	11823-2, LN, Cephalic Index
FL/HC	11873-7, LN, FL/HC
HrtC/TC	C12004-01, MRUS, HrtC/TC
TCD/AC	C12004-02, MRUS, TCD/AC
LVW/HW	C12004-03, MRUS, LVW/HW
CIHC	C12004-04, MRUS, Cephalic Index by HC
AC	11979-2, LN, Abdominal Circumference
BPD	11820-8, LN, Biparietal Diameter
FL	11963-6, LN, Femur Length
HC	11984-2, LN, Head Circumference
OFD	11851-3, LN, Occipital-Frontal Diameter
APAD	11818-2, LN, Anterior-Posterior Abdominal Diameter
TC	11988-3, LN, Thoracic Circumference
TAD	11862-0, LN, Transverse Abdominal Diameter
TTD	11864-6, LN, Transverse Thoracic Diameter
APTD	11819-0, LN, Anterior-Posterior Trunk Diameter
FTA	33068-8, LN, Thoracic Area
TCD	11863-8, LN, Trans Cerebellar Diameter
Foot	11965-1, LN, Foot length
Cist Magna	11860-4, LN, Cisterna Magna
AXT	33191-8, LN, APAD * TAD
F-kidney	M12005-05, MRUS, Fetal Kidney length
THD	M12005-01, MRUS, Thoracic Diameter
HrtC	M12005-02, MRUS, Heart Circumference

<i>MODALITY</i>	<i>DICOM Mapping</i>
<i>Label</i>	
HUM	11966-9, LN, Humerus length
RAD	11967-7, LN, Radius length
Ulna	11969-3, LN, Ulna length
Tibia	11968-5, LN, Tibia length
FIB	11964-4, LN, Fibula length
CLAV	11962-8, LN, Clavicle length
LVW	12171-5, LN, Lateral Ventricular width
NF	12146-7, LN, Nuchal Fold thickness
IOD	33070-4, LN, Inner Orbital Diameter
OOD	11629-3, LN, Outer Orbital Diameter
TCD	11863-8, LN, Trans Cerebellar Diameter
NT	33069-6, LN, Nuchal Translucency
HW	12170-7, LN, Width of Hemisphere
Ear	M12007-01, MRUS, Ear Length
MP	M12007-02, MRUS, Middle Phalanx Length
Orbit	M12007-03, MRUS, Orbit
OFD(HC)	M12007-04, MRUS, OFDHC
HC(c)	C12007-01, MRUS, HCc
AF1	11624-4, LN, First Quadrant Diameter
AF2	11626-9, LN, Second Quadrant Diameter
AF3	11625-1, LN, Third Quadrant Diameter
AF4	11623-6, LN, Fourth Quadrant Diameter
AF	M12008-01, MRUS, Amniotic Fluid
CRL	11957-8, LN, Crown Rump Length
GS	11850-5, LN, Gestational Sac Diameter
Vertebrae	33071-2, LN, Spine Length
YS	11816-6, LN, Yolk Sac length
NT	33069-6, LN, Nuchal Translucency
Mean Sac Diam	C12009-01, MRUS, Mean Gestational Sac Diameter
Cervix L	11961-0, LN, Cervix Length
Cervix L	11961-0, LN, Cervix Length
Endo	12145-9, LN, Endometrium Thickness
Cervix H	M12011-01, MRUS, Cervix Height
Cervix W	M12011-02, MRUS, Cervix Width



M7 Series Diagnostic Ultrasound System

<i>MODALITY Label</i>	<i>DICOM Mapping</i>
Uterus Body	C12011-03,MRUS,Uterus Body
UT-L/CX-L	C12011-04,MRUS,UT_L/CX_L
Mat Kidney	M12011-03,MRUS,Matrix Kidney Length
AFI	11627-7,LN,Amniotic Fluid Index
Ovary W	11829-9, LN, Left Ovary Width;11830-7, LN, Right Ovary Width
Ovary L	11840-6, LN, Left Ovary Length;11841-4, LN, Right Ovary Length
Ovary H	11857-0, LN, Left Ovary Height;11858-8, LN, Right Ovary Height
Ovary Vol	12164-0, LN, Left Ovary Volume;12165-7, LN, Right Ovary Volume
Follicle1 L	M11793-02, MRUS, Follicle Length
Follicle2 L	M11793-02, MRUS, Follicle Length
Follicle3 L	M11793-02, MRUS, Follicle Length
Follicle4 L	M11793-02, MRUS, Follicle Length
Follicle5 L	M11793-02, MRUS, Follicle Length
Follicle6 L	M11793-02, MRUS, Follicle Length
Follicle7 L	M11793-02, MRUS, Follicle Length
Follicle8 L	M11793-02, MRUS, Follicle Length
Follicle9 L	M11793-02, MRUS, Follicle Length
Follicle10 L	M11793-02, MRUS, Follicle Length
Follicle11 L	M11793-02, MRUS, Follicle Length
Follicle12 L	M11793-02, MRUS, Follicle Length
Follicle13 L	M11793-02, MRUS, Follicle Length
Follicle14 L	M11793-02, MRUS, Follicle Length
Follicle15 L	M11793-02, MRUS, Follicle Length
Follicle16 L	M11793-02, MRUS, Follicle Length
UT W	11865-3,LN,Uterus Width
UT L	11842-2,LN,Uterus Length
UT H	11859-6,LN,Uterus Height
UT Vol	33192-6,LN,Uterus Volume
Follicle1 W	M11793-01,MRUS,Follicle Width
Follicle2 W	M11793-01,MRUS,Follicle Width
Follicle3 W	M11793-01,MRUS,Follicle Width
Follicle4 W	M11793-01,MRUS,Follicle Width
Follicle5 W	M11793-01,MRUS,Follicle Width
Follicle6 W	M11793-01,MRUS,Follicle Width



M7 Series Diagnostic Ultrasound System

<i>MODALITY</i> <i>Label</i>	<i>DICOM Mapping</i>
Follicle7 W	M11793-01,MRUS,Follicle Width
Follicle8 W	M11793-01,MRUS,Follicle Width
Follicle9 W	M11793-01,MRUS,Follicle Width

<i>MODALITY</i> <i>Label</i>	<i>DICOM Mapping</i>
Follicle9 Diam	11793-7,LN,Follicle Diameter
Follicle10 Diam	11793-7,LN,Follicle Diameter
Follicle11 Diam	11793-7,LN,Follicle Diameter
Follicle12 Diam	11793-7,LN,Follicle Diameter
Follicle13 Diam	11793-7,LN,Follicle Diameter
Follicle14 Diam	11793-7,LN,Follicle Diameter
Follicle15 Diam	11793-7,LN,Follicle Diameter
Follicle16 Diam	11793-7,LN,Follicle Diameter
EFW1	11727-5,LN,Estimated Weight
EFW2	11727-5,LN,Estimated Weight
CP	11767-1,LN, EFW percentile rank
UP	11767-1,LN, EFW percentile rank
CP	11767-1,LN, EFW percentile rank
UP	11767-1,LN, EFW percentile rank
EFW(Campbell)	11727-5,LN,Estimated Weight
EFW(Hadlock1)	11727-5,LN,Estimated Weight
EFW(Hadlock2)	11727-5,LN,Estimated Weight
EFW(Hadlock3)	11727-5,LN,Estimated Weight
EFW(Hadlock4)	11727-5,LN,Estimated Weight
EFW(Hansmann)	11727-5,LN,Estimated Weight
EFW(Merz1)	11727-5,LN,Estimated Weight
EFW(Merz2)	11727-5,LN,Estimated Weight
EFW(Osaka)	11727-5,LN,Estimated Weight
EFW(Shepard)	11727-5,LN,Estimated Weight
EFW(Tokyo)	11727-5,LN,Estimated Weight
EFW(Schild)	11727-5,LN,Estimated Weight
EFW(Persson)	11727-5,LN,Estimated Weight
PL Thickness	M12011-01,MRUS,Placental Thickness
Sac Diam1	M12009-01,MRUS,Gestational Sac Diameter1
Sac Diam2	M12009-02,MRUS,Gestational Sac Diameter2
Sac Diam3	M12009-03,MRUS,Gestational Sac Diameter3

A.48.2. Vasculature Anatomic Location

<i>MODALITY Vasculature Anatomic Location</i>	<i>DICOM Mapping</i>
Ovarian A	T-46980, SRT, Ovarian Artery
Ut A	T-46820, SRT, Uterine Artery
Fetal Ao	T-42000, SRT, Aorta
Desc Aorta	T-D0765, SRT, Descending Aorta
MCA	T-45600, SRT, Middle Cerebral Artery
Duct Venos	V12141-01, MRUS, Ductus Venos
Umb A	T-F1810, SRT, Umbilical Artery
Umb V	T-F1820, SRT, Umbilical Vein
Placenta A	T-F1412, SRT, Vitelline Artery of Placenta

A.48.3. OB-GYN Vascular Measurements

<i>MODALITY Label</i>	<i>DICOM Mapping</i>
<Vasculature Anatomic Location> ED	11653-3, LN, End Diastolic Velocity
<Vasculature Anatomic Location> MD	11665-7, LN, Minimum Diastolic Velocity
<Vasculature Anatomic Location> PS	11726-7, LN, Peak Systolic Velocity
<Vasculature Anatomic Location> TAMEAN	20352-1, LN, Time averaged mean velocity
<Vasculature Anatomic Location> TAMAX	11692-1, LN, Time averaged peak velocity
<Vasculature Anatomic Location> PV	11726-7, LN, Peak Velocity
<Vasculature Anatomic Location> PI	12008-9, LN, Pulsatility Index
<Vasculature Anatomic Location> RI	12023-8, LN, Resistivity Index
<Vasculature Anatomic Location> S/D	12144-2, LN, Systolic to Diastolic Velocity Ratio
<Vasculature Anatomic Location> D	M12119-04, MRUS, Diastolic to Systolic Velocity Ratio
<Vasculature Anatomic Location> D	M12120-1, MRUS, Peak Early Diastolic Velocity
<Vasculature Anatomic Location> PVIV	C12121-2, MRUS, Peak velocity index for the vein
<Vasculature Anatomic Location> AT	20168-1, LN, Acceleration Time
<Vasculature Anatomic Location> DT	20217-6, LN, Deceleration Time
<Vasculature Anatomic Location> PPG	20247-3, LN, Peak Gradient
<Vasculature Anatomic Location> MPG	20256-4, LN, Mean Gradient
<Vasculature Anatomic Location> MMPG	M12119-01, MRUS, Mean Velocity Mean Pressure Gradient
<Vasculature Anatomic Location> VTI	M12119-02, MRUS, Velocity-Time Integral
<Vasculature Anatomic Location> HR	11948-7, LN, Fetal Heart Rate
<Vasculature Anatomic Location> +	M12119-03, MRUS, Angle
<Vasculature Anatomic Location> VD	R-1025C, SRT, Vessel Intimal Diameter
<Vasculature Anatomic Location> VolFlow	M12119-06, MRUS, Vol Flow(TAMAX)
<Vasculature Anatomic Location> VolFlow.TAMEAN	M12119-07, MRUS, Vol Flow(TAMEAN)

A.48.4. OB-GYN Cardiac Measurements

<i>MODALITY Label</i>	<i>DICOM Mapping</i>
Ao Diam	18015-8, LN, Aortic Root Diameter
MPA Diam	Main Pulmonary Artery Diameter
IVSd	18154-5, LN, Interventricular Septum Diastolic Thickness
IVSs	18158-6, LN, Interventricular Septum Systolic Thickness
LVD/RVD	C12201-06, MRUS, Left Ventricular Diameter/Right Ventricular Diameter
LAD/RAD	C12205-03, MRUS, Left Atrium Diameter / Right Atrium Diameter
LAD/AoD	C12205-04, MRUS, Left Atrium Diameter / Aorta Diameter
AoD/MPAD	C12212-01, MRUS, Aorta Diameter/Main Pulmonary Artery Diameter
LVIDd	M12201-01, MRUS, Left ventricular short-axis diameter at end diastole
LVIDs	M12201-02, MRUS, Left ventricular short-axis diameter at end systole
LV Diam	M12201-03, MRUS, Left ventricular Diameter
IVS	M12201-04, MRUS, interventricular septal thickness
LVOT Diam	M12201-05, MRUS, Left Ventricular Outflow Tract Diameter
RVIDd	M12204-01, MRUS, Right ventricular short-axis diameter at end diastole
RVIDs	M12204-02, MRUS, Right ventricular short-axis diameter at end systole
RV Diam	M12204-03, MRUS, Right ventricular Diameter
RA Diam	M12206-01, MRUS, Right Atrium Diameter
RV Area	M12204-04, MRUS, Right ventricular area
RVOT Diam	M12204-05, MRUS, Right Ventricular Outflow Tract Diameter
LA Diam	M12205-01, MRUS, Left Atrium Diameter
LA Area	M12205-02, MRUS, Left Atrium area
RA Area	M12206-02, MRUS, Right Atrium area
LV Area	M12240-01, MRUS, Left ventricular area

A.48.5. Biophysical Profile Measurements

<i>MODALITY Label</i>	<i>DICOM Mapping</i>
FM	11631-9, LN, Gross Body Movement
FBM	11632-7, LN, Fetal Breathing
FT	11635-0, LN, Fetal Tone
FHR	11635-5, LN, Fetal Heart Reactivity
AF	11630-1, LN, Amniotic Fluid Volume
Total Score	11634-3, LN, Biophysical Profile Sum Score
Fetal Lie	FG12018-02, MRUS, Fetal Lie
Gender	FG7455-01, MRUS, Gender
3 Vessel Cord	FG7160-01, MRUS, 3 Vessel Cord
Face	T-D1200, SNM3, Face
Nose Lips	FG4-01, MRUS, Nose Lips
Cord insertion	FG12011-01, MRUS, Cord insertion
LUS	FG4031-02, MRUS, LUS



M7 Series Diagnostic Ultrasound System

Stomach	T-57000,SNM3,Stomach
Left Kidney	T-71000,SRT,Kidney
Right Kidney	T-71000,SRT,Kidney
Bladder	T-74000,SRT,Bladder
Gall Bladder	T-63000,SRT,Gall bladder
Liver	T-62000,SRT,Liver
Fetal Bowel	FG4031-03,MRUS,Fetal Bowel
Upper Extremities	FG4031-05,MRUS,Upper Extremities
Lower Extremities	FG4031-06,MRUS,Lower Extremities
Cardiac Activity	FG12239-01,MRUS,Cardiac Activity
4C HEART	FG4031-08,MRUS,4C HEART
Aorta	T-42000,SNM3,Aorta
Pulmonary Artery	T-44000,SNM3,Pulmonary Artery
ARCH	FG3010-01,MRUS,ARCH
Lateral Ventricles	FG4030-02,MRUS,Lateral Ventricles
Cisterna Magna	11860-4,LN,Cisterna Magna
Cerebellum	T-A600A,SNM3,Cerebellum
CSP	FG4030-03,MRUS,CSP
Cervical Spine	T-11501,SNM3,Cervical Spine
Thoracic Spine	T-11502,SNM3,Thoracic Spine

B. Appendix : Cardiac structured reporting template

This appendix lists the DICOM Structured Report (SR) mappings used in the Cardiac Structured Reports of ultrasound system SR files.

The mappings are organized in a manner similar to the DICOM SR Templates as described in PS 3.16 of the DICOM Standard. The Cardiac Report mappings follow the DICOM SR Template TID 5200: Cardiac Ultrasound Procedure Report, except where noted.

All private code values use the Coding Scheme Designator "MRUS".

B.1. TID (5200) Echocardiography Procedure Report

This template forms the top of a content tree that allows an ultrasound system to describe the results of an adult echocardiography imaging procedure.

	NL	Rel with Parent	VT	Concept Name	Used in MODALITY	Condition	Value Set Constraint
1			CONTAINER	EV (125200, DCM, "Adult Echocardiography Procedure Report")	✓		
2	>	HAS CONCEPT MOD	INCLUDE	DTID (1204) Language of Content Item and Descendants			
3	>	HAS OBS CONTEXT	INCLUDE	DTID (1001) Observation Context	✓		
4	>	CONTAINS	INCLUDE	DTID (5201) Echocardiography Patient Characteristics	✓		
5	>	CONTAINS	CONTAINER	(111028, DCM, "Image Library")			
6	>>	CONTAINS	IMAGE	No purpose of reference			
7	>	CONTAINS	INCLUDE	DTID(SELFTEM-2)Echo Procedure Summary Section	✓		
8	>	CONTAINS	INCLUDE	DTID (5202) Echo Section	✓		\$\$SectionSubject = EV (T-32600, SRT, "Left Ventricle") \$MeasType = DCID (12200)



M7 Series Diagnostic Ultrasound System

							Echocardiography Left Ventricle
9	>	CONTAINS	INCLUDE	DTID (5202) Echo Section	√		\$\$SectionSubject = EV (T-32500, SRT, "Right Ventricle") \$MeasType = DCID (12204) Echocardiography Right Ventricle
10	>	CONTAINS	INCLUDE	DTID (5202) Echo Section	√		\$\$SectionSubject = EV (T-32300, SRT, "Left Atrium") \$MeasType = DCID (12205) Echocardiography Left Atrium
11	>	CONTAINS	INCLUDE	DTID (5202) Echo Section	√		\$\$SectionSubject = EV (T-32200, SRT, "Right Atrium") \$MeasType = DCID (12206) Echocardiography Right Atrium
12	>	CONTAINS	INCLUDE	DTID (5202) Echo Section	√		\$\$SectionSubject = EV (T-35400, SRT, "Aortic Valve") \$MeasType = DCID (12211) Echocardiography Aortic Valve
13	>	CONTAINS	INCLUDE	DTID (5202) Echo Section	√		\$\$SectionSubject = EV (T-35300, SRT, "Mitral Valve") \$MeasType = DCID (12207) Echocardiography Mitral Valve
14	>	CONTAINS	INCLUDE	DTID (5202) Echo Section	√		\$\$SectionSubject =



M7 Series Diagnostic Ultrasound System

							EV (T-35200, SRT, "Pulmonic Valve") \$MeasType = DCID (12209) Echocardiography Pulmonic Valve
15	>	CONTAINS	INCLUDE	DTID (5202) Echo Section	√		\$SectionSubject = EV (T-35100, SRT, "Tricuspid Valve") \$MeasType = DCID (12208) Echocardiography Tricuspid Valve
16	>	CONTAINS	INCLUDE	DTID (5202) Echo Section	√		\$SectionSubject = EV (T-42000, SRT, "Aorta") \$MeasType= DCID (12212) Echocardiography Aorta
17	>	CONTAINS	INCLUDE	DTID (5202) Echo Section	√		\$SectionSubject = EV (T-44000, SRT, "Pulmonary artery") \$MeasType DCID (12210) = Echocardiography Pulmonary Artery
18	>	CONTAINS	INCLUDE	DTID (5202) Echo Section	√		\$SectionSubject = EV (T-48600, SRT, "Vena Cava") \$MeasType = DCID (12215) Echocardiography Vena Cavae
19	>	CONTAINS	INCLUDE	DTID (5202) Echo Section	√		\$SectionSubject = EV (T-48581, SRT, "Pulmonary Venous Structure")



M7 Series Diagnostic Ultrasound System

							\$MeasType = DCID (12214) Echocardiography Pulmonary Veins
20	>	CONTAINS	INCLUDE	DTID (5202) Echo Section	✓		\$SectionSubject = EV (P5-30031, SRT, "Cardiac Shunt Study") \$MeasType = DCID (12217) Echocardiography Cardiac Shunt
21	>	CONTAINS	INCLUDE	DTID (5202) Echo Section	✓		\$SectionSubject = EV (D4-30000, SRT, "Congenital Anomaly of Cardiovascular System") \$MeasType = DCID (12218) Echocardiography Congenital
22	>	CONTAINS	INCLUDE	DTID (5204) Wall Motion Analysis			
23	>	CONTAINS	INCLUDE	DTID (5202) Echo Section	✓		\$SectionSubject = EV (D3-90000, SRT, "Pericardial disease") \$MeasType = DCID (90000) Pericardial disease
24	>	CONTAINS	INCLUDE	DTID (5202) Echo Section	✓		\$SectionSubject = EV (G-0394, SRT, "Heart rate") \$MeasType = DCID (12220) Echocardiography Common Measurements
25	>	CONTAINS	TEXT	(20121120,MRUS, "self-defined-measurementfile")			



B.2. TID(1001) Observation Context

This template specifies attributes of observation context that may be defined, extended or replaced at any location in the SR tree.

NL	Rel	with	VT	Concept Name	Used	in	Condition	Value Set Constraint
	Parent					MODALITY		



M7 Series Diagnostic Ultrasound System

1			CONTAINER	EV (121118, DCM, "Patient Characteristics")	✓		
2	>	CONTAINS	NUM	EV (121033, DCM, "Subject Age")	✓		



M7 Series Diagnostic Ultrasound System

5	>	CONTAINS	TEXT	(I12101-03,MRUS,"CPT4 Code")	✓		from Info
6	>	CONTAINS	TEXT	(I12101-04,MRUS,"CPT4 Description")	✓		from Info
	>	CONTAINS	TEXT	EV (121106, DCM, "Comment")	✓		from report interface Comment
8	>	CONTAINS	TEXT	(I12101-05,MRUS,"Prompt")	✓		from report interface Comment
9	>	CONTAINS	TEXT	(121071,DCM,"Findings")	✓		from report interface Comment

B.5. TID (5202) ECHO SECTION

	NL	Rel with Parent	VT	Concept Name	Used in MODALITY	Value Set Constraint	Comment
1			CONTAINER	EV (121070, DCM, "Findings")	✓		
2	>	HAS CONCEPT MOD	CODE	EV (G-C0E3, SRT, "Finding Site")	✓	\$SectionSubject = EV (T-32600, SRT, "Left Ventricle")	
3	>	CONTAINS	CONTAINER	DT (125007, DCM, "Measurement Group")	✓		
4	>>	HAS CONCEPT MOD	CODE	EV (G-0373, SRT, "Image Mode")		BCID (12224) Ultrasound Image Modes	
5	>>	HAS CONCEPT MOD	CODE	DT (125203,DCM,"Acquisition Protocol")			
6	>>	CONTAINS	INCLUDE	DTID (5203) Echo Measurement	✓	\$Measurement=\$MeasType = DCID (12200) Echocardiography Left Ventricle \$Method=CID (12227) Echocardiography	



M7 Series Diagnostic Ultrasound System

						Measurement Method	
--	--	--	--	--	--	--------------------	--

B.6. TID (5203) Echo Measurement

	NL	Relation with Parent	Value Type	Concept Name	Used in MODALITY	Value Set Constraint	Comment
1			INCLUDE	DTID (300) Measurement	✓	\$Measurement = \$Measurement \$Method = \$Method \$TargetSite = BCID (12236) Echo Anatomic Sites \$TargetSiteMod = BCID (12237) Echocardiography Anatomic Site Modifiers	
2	>	HAS CONCEPT MOD	CODE	EV(G-C036,SRT,"Measurement Method")	✓	This row is used only if the measurement or calculation this template is invoked with mandates it. Otherwise this row is not used. The values are taken from the BCID 12227	
3	>	HAS CONCEPT MOD	CODE	EV (G-C048, SRT, "Flow Direction")	✓	BCID (12221) Flow Direction	
4	>	HAS CONCEPT MOD	CODE	EV (R-40899, SRT, "Respiratory Cycle Point")		DCID (12234) Respiration State	



M7 Series Diagnostic Ultrasound System

5	>	HAS CONCEPT MOD	CODE	EV (R-4089A, SRT, “Cardiac Cycle Point”)	✓	DCID (12233) Respiration State	
6	>	HAS ACQ CONTEXT	CODE	EV (G-0373, SRT, “Image Mode”)	✓	DCID (12224) Ultrasound Image Modes	
7	>	HAS ACQ CONTEXT	CODE	EV (111031, DCM, “Image View”)	✓	BCID (12226) Echocardiography Image View	

B.7. CID (12200) Echocardiography Left Ventricle

INCLUDE CID 12220 Echocardiography Common Measurements
INCLUDE CID 12201 Left Ventricle Linear
INCLUDE CID 12240 Left Ventricle Area
INCLUDE CID 12202 Left Ventricle Volume
INCLUDE CID 12222 Orifice Flow Properties
INCLUDE CID 12203 Left Ventricle Other
INCLUDE CID 12239 Cardiac Output Properties

B.8. CID (12201) Left Ventricle Linear

CSD	CV	Code Meaning
LN	29436-3	Left Ventricle Internal End Diastolic Dimension
LN	29438-9	Left Ventricle Internal Systolic Dimension
LN	18051-3	Left Ventricular Fractional Shortening
LN	18154-5	Interventricular Septum Diastolic Thickness
LN	18155-2	Interventricular Septum to Posterior Wall Thickness Ratio
LN	18054-7	Interventricular Septum % Thickening
LN	18158-6	Interventricular Septum Systolic Thickness
LN	18053-9	Left Ventricle Posterior Wall % Thickening
LN	18077-8	Left Ventricle diastolic major axis
LN	18076-0	Left Ventricle systolic major axis
LN	18156-0	Left Ventricle Posterior Wall Systolic Thickness
LN	18152-9	Left Ventricle Posterior Wall Diastolic Thickness
MRUS	M12201-01	Left ventricular Major

MRUS	M12201-02	Left ventricular Minor
MRUS	C12201-01	Mean Velocity of Circumferential Fiber Shortening
MRUS	M12201-03	A Distance
MRUS	M12201-04	B Distance
MRUS	M12201-05	Left ventricular internal diameter to BSA Ratio

B.9. CID (12202) Left Ventricle Volume

CSD	CV	Code Meaning
LN	18026-5	Left Ventricular End Diastolic Volume
LN	18148-7	Left Ventricular End Systolic Volume
LN	18043-0	Left Ventricular Ejection Fraction

B.10. CID (12203) Left Ventricle Other

CSD	CV	Code Meaning
LN	18087-7	Left Ventricle Mass
LN	18071-1	Left Ventricular Isovolumic Relaxation Time
SRT	G-037E	Left Ventricular Isovolumic Contraction Time
SRT	G-037F	Left Ventricular Index of Myocardial Performance
MRUS	M12203-01	Left Ventricle Pre-Ejection Period
MRUS	M12203-02	Left Ventricle Ejection Time
MRUS	C12203-01	Left ventricular Mass Weight Index
MRUS	C12203-02	Left Ventricle Pre-Ejection Period to Ejection Time Ratio

B.11. CID (12204) Echocardiography Right Ventricle

CSD	CV	Code Meaning
INCLUDE CID 12220 Echocardiography Common Measurements		
INCLUDE CID 12222 Orifice Flow Properties		
INCLUDE CID 12239 Cardiac Output Properties		
LN	20304-2	Right Ventricular Internal Diastolic Dimension
LN	20305-9	Right Ventricular Internal Systolic Dimension
SRT	G-0381	Right Ventricular Index of Myocardial Performance
SRT	G-0380	Right Ventricular Peak Systolic Pressure
LN	18153-7	Right Ventricular Anterior Wall Diastolic Thickness
LN	18157-8	Right Ventricular Anterior Wall Systolic Thickness

CSD	CV	Code Meaning
MRUS	M12204-01	Right ventricular Major
MRUS	M12204-02	Right ventricular Minor
MRUS	M12204-03	Right ventricular Area at end-diastole
MRUS	M12204-04	Right ventricular Area at end-systole
MRUS	M12204-05	Right Ventricle Pre-Ejection Period
MRUS	M12204-06	Right Ventricle Ejection Time
MRUS	C12204-01	Right Ventricle Pre-Ejection Period to Ejection Time Ratio

B.12. CID (12205) Echocardiography Left Atrium

CSD	CV	Code Meaning
INCLUDE CID 12220 Echocardiography Common Measurements		
LN	29469-4	Left Atrium Antero-posterior Systolic Dimension
LN	17985-3	Left Atrium to Aortic Root Ratio
LN	17977-0	Left Atrium Systolic Area
SRT	G-0383	Left Atrium Systolic Volume
MRUS	M12205-01	Left atrium Major
MRUS	M12205-02	Left atrium Minor
MRUS	C12205-01	Aortic Root to Left Atrium Ratio

B.13. CID (12206) Echocardiography Right Atrium

CSD	CV	Code Meaning
INCLUDE CID 12220 Echocardiography Common Measurements		
LN	17988-7	Right Atrium Systolic Area
MRUS	M12206-01	Right atrium Major
MRUS	M12206-02	Right atrium Minor
MRUS	M12206-03	Right atrium Volume

B.14. CID (12207) Echocardiography Mitral Valve

CSD	CV	Code Meaning
SRT	F-32120	Stroke Volume
INCLUDE CID 12220 Echocardiography Common Measurements		

CSD	CV	Code Meaning
MRUS	M12207-25	Deceleration Time of Early diastolic velocity
MRUS	M12207-26	Deceleration Rate of Early diastolic velocity
MRUS	M12207-27	Mitral Stenosis Radius
MRUS	M12207-28	Mitral Stenosis Aliasing Velocity
MRUS	M12207-29	Mitral Stenosis Maximum Velocity
MRUS	M12207-30	Mitral Stenosis Area
MRUS	C12207-01	Mitral Stenosis Maximum Pressure Gradient

B.15. CID (12208) Echocardiography Tricuspid Valve

CSD	CV	Code Meaning
INCLUDE CID 12220 Echocardiography Common Measurements		
INCLUDE CID 12222 Orifice Flow Properties		
LN	18031-5	Tricuspid Valve E Wave Peak Velocity
LN	18030-7	Tricuspid Valve A Wave Peak Velocity
LN	18039-8	Tricuspid Valve E to A Ratio
SRT	G-0389	Tricuspid Valve Closure to Opening Time
MRUS	M12208-01	Tricuspid Valve E-Wave Duration
MRUS	M12208-02	Tricuspid Valve E Wave Pressure Gradient
MRUS	M12208-03	Tricuspid Valve A Wave Pressure Gradient
MRUS	M12207-35	MV E/Ea

B.16. CID (12209) Echocardiography Pulmonic Valve

INCLUDE CID 12220 Echocardiography Common Measurements
INCLUDE CID 12222 Orifice Flow Properties

B.17. CID (12210) Echocardiography Pulmonary Artery

CSD	CV	Code Meaning
INCLUDE CID 12220 Echocardiography Common Measurements		
LN	18020-8	Main Pulmonary Artery Diameter
LN	18021-6	Right Pulmonary Artery Diameter
LN	18019-0	Left Pulmonary Artery Diameter
SRT	G-038A	Main Pulmonary Artery Peak Velocity
MRUS	M12210-01	Posterior ductal Diameter

CSD	CV	Code Meaning
MRUS	C12210-01	Pulmonary Artery End Diastolic Pressure

B.18. CID (12211) Echocardiography Aortic Valve

CSD	CV	Code Meaning
INCLUDE CID 12220 Echocardiography Common Measurements		
INCLUDE CID 12222 Orifice Flow Properties		
LN	17996-0	Aortic Valve Cusp Separation
SRT	G-0382	Ratio of Aortic Valve Acceleration Time to Ejection Time

B.19. CID (12212) Echocardiography Aorta

CSD	CV	Code Meaning
INCLUDE CID 12220 Echocardiography Common Measurements		
LN	18015-8	Aortic Root Diameter
LN	18011-7	Aortic Arch Diameter
LN	18012-5	Ascending Aortic Diameter
LN	18014-1	Aortic Isthmus Diameter
LN	18013-3	Descending Aortic Diameter
MRUS	M12212-01	Aortic Sinotubular junction Diameter
MRUS	M12212-02	Aortic Sinus Diameter
MRUS	M12212-03	Ductus Artery Diameter
MRUS	M12212-04	Previous Ductal Diameter
MRUS	M12212-05	Left Coronary Artery Diameter
MRUS	M12212-06	Right Coronary Artery Diameter
MRUS	C12212-02	Aortic Sinotubular junction Diameter/Aorta Root Diameter

B.20. CID (12214) Echocardiography Pulmonary Veins

CSD	CV	Code Meaning
INCLUDE CID 12220 Echocardiography Common Measurements		
SRT	G-038B	Pulmonary Vein A-Wave Duration
SRT	G-038D	Pulmonary Vein D-Wave Velocity Time Integral/
SRT	G-038C	Pulmonary Vein S-Wave Velocity Time Integral
MRUS	M12214-01	Pulmonary Vein S wave flow Velocity
MRUS	M12214-02	Pulmonary Vein D-wave flow Velocity



CSD	CV	Code Meaning
MRUS	M12214-03	Pulmonary Vein A-wave flow Velocity
MRUS	M12214-04	Pulmonary Vein Deceleration Time
MRUS	M12214-05	Pulmonary Vein Ratio of S-Wave velocity to D-wave velocity
MRUS	M12214-06	Pulmonary Vein Systolic fraction

B.21. CID (12215) Echocardiography Vena Cavae

CSD	CV	Code Meaning
-----	----	--------------

B.24. CID (12220) Echocardiography Common Measurements

CSD	CV	Code Meaning
LN	8867-4	Heart rate

B.25. CID (12221) Flow Direction

CSD	CV	Code Meaning
SRT	R-42047	Antegrade Flow
SRT	R-42E61	Regurgitant Flow

B.26. CID (12222) Orifice Flow Properties

CSD	CV	Code Meaning
SRT	G-038E	Cardiovascular Orifice Area
SRT	G-038F	Cardiovascular Orifice Diameter
SRT	G-0390	Regurgitant Fraction
LN	11726-7	Peak Velocity
LN	20352-1	Mean Velocity
LN	20247-3	Peak Gradient
LN	20256-4	Mean Gradient
LN	20354-7	Velocity Time Integral
LN	20168-1	Acceleration Time
LN	11653-3	End Diastolic Velocity
LN	20280-4	Pressure Half-Time
LN	20217-6	Deceleration Time
LN	33878-0	Volume Flow
LN	34141-2	Peak Instantaneous Flow Rate
LN	20216-8	Deceleration Slope
MRUS	M12222-05	Aliasing Velocity
MRUS	M12222-04	Time
MRUS	M12222-02	Acceleration Slope
MRUS	M12222-06	Flow Radius



M7 Series Diagnostic Ultrasound System

CSD

CV

Code Meaning

B.29. CID (12227) Echocardiography Measurement Method

INCLUDE CID 12228 Echocardiography Volume Methods
INCLUDE CID 12229 Echocardiography Area Methods
INCLUDE CID 12231 Volume Flow Methods
INCLUDE CID 12232 Myocardium Mass Methods

B.30. CID (12228) Volume Methods

CSD	CV	Code Meaning
DCM	125204	Area-Length Biplane
DCM	125205	Area-Length Single Plane
DCM	125211	Biplane Ellipse
DCM	125226	Single Plane Ellipse
DCM	125206	Cube Method
DCM	125207	Method of Disks, Biplane
DCM	125208	Method of Disks, Single Plane
DCM	125209	Teichholz
MRUS	VM12228-01	Bullet
MRUS	VM12228-02	Method of Disks,Simpson
MRUS	VM12228-03	Gibson

B.31. CID (12229) Area Methods

CSD	CV	Code Meaning
DCM	125210	Area by Pressure Half-Time
DCM	125212	Continuity Equation
DCM	125213	Continuity Equation by Mean Velocity
DCM	125214	Continuity Equation by Peak Velocity
DCM	125215	Continuity Equation by Velocity Time Integral
DCM	125216	Proximal Isovelocity Surface Area
DCM	125220	Planimetry

B.32. CID (12230) Gradient Methods

CSD	CV	Code Meaning
-----	----	--------------

CSD	CV	Code Meaning
DCM	125217	Full Bernoulli
DCM	125218	Simplified Bernoulli

B.33. CID (12231) Volume Flow Methods

CSD	CV	Code Meaning
DCM	125219	Doppler Volume Flow
DCM	125216	Proximal Isovelocity Surface Area

B.34. CID (12232) Myocardium Mass Methods

CSD	CV	Code Meaning
DCM	125221	Left Ventricle Mass by M-mode
DCM	125222	Left Ventricle Mass by Truncated Ellipse

B.35. CID (12233) Cardiac Phase

CSD	CV	Code Meaning
SRT	F-32020	Systole
SRT	F-32010	Diastole
SRT	F-32011	End Diastole
DCM	109070	End Systole

B.36. CID (12234) Respiration Phase

CSD	CV	Code Meaning
SRT	F-20010	During Inspiration
SRT	F-20020	During Expiration

B.37. CID (12239) Cardiac Output Properties

CSD	CV	Code Meaning
SRT	F-32120	Stroke Volume
SRT	F-32100	Cardiac Output
SRT	F-32110	Cardiac Index
SRT	F-00078	Stroke Index
SRT	F-04FD8	RV Stroke Volume

CSD	CV	Code Meaning
SRT	F-04FE5	RV Stroke Index
SRT	F-04FA5	RV Cardiac Output
SRT	F-04F84	RV Cardiac Index

B.38. CID (12240) Left Ventricle Area

CSD	CV	Code Meaning
SRT	G-0374	Left Ventricular Systolic Area
SRT	G-0375	Left Ventricular Diastolic Area
SRT	G-0379	Left Ventricle Epicardial Diastolic Area, psax pap view
MRUS	M12240-01	Left Ventricle Endocardiac Diastolic Area, psax pap view

B.39. CID (90000) Pericardial disease

CSD	CV	Code Meaning
MRUS	C90000-01	Pericard Effusion at end-diastole
MRUS	C90000-02	Pericard Effusion at end-systole

B.40. Mapping between Modality measurements and DICOM Concepts.
B.40.1. Left Ventricle Measurements

<i>MODALITY Label</i>	<i>DICOM Mapping</i>	<i>Optional Modifiers</i>
LVOT HR	8867-4, LN, Heart rate	
LVIDd(2D)	29436-3, LN, Left Ventricle Internal End Diastolic Dimension	ImageMode = G-03A2, SRT, 2D mode;
LVIDd Cube(2D)	29436-3, LN, Left Ventricle Internal End Diastolic Dimension	ImageMode = G-03A2, SRT, 2D mode; Method = 125206, DCM, Cube Method
LVIDd Teich(2D)	29436-3, LN, Left Ventricle Internal End Diastolic Dimension	ImageMode = G-03A2, SRT, 2D mode; Method = 125209, DCM, Teichholz
LVIDd Gibson(2D)	29436-3, LN, Left Ventricle Internal End Diastolic Dimension	ImageMode = G-03A2, SRT, 2D mode; Method = VM12228-03, MRUS, Gibson
LVIDd Gibson(M)	29436-3, LN, Left Ventricle Internal End Diastolic Dimension	ImageMode = G-0394, SRT, M Mode; Method = VM12228-03, MRUS, Gibson



M7 Series Diagnostic Ultrasound System

LVIDd Cube(M)	29436-3, LN, Left Ventricle Internal End Diastolic Dimension	ImageMode = G-0394, SRT, M Mode; Method =125206, DCM, Cube Method
LVIDd Teich(M)	29436-3, LN, Left Ventricle Internal End Diastolic Dimension	ImageMode = G-0394, SRT, M Mode; Method =125209, DCM, Teichholz
LVIDd LV Mass(Cube)(2D)	29436-3, LN, Left Ventricle Internal End Diastolic Dimension	ImageMode = G-03A2, SRT, 2D mode;
LVIDd LV Mass(Cube)(M)	29436-3, LN, Left Ventricle Internal End Diastolic Dimension	ImageMode = G-0394, SRT, M Mode; Method =125221, DCM, Left Ventricle Mass by M-mode
LVIDd(BP Ellipse)	29436-3, LN, Left Ventricle Internal End Diastolic Dimension	ImageMode = G-03A2, SRT, 2D mode; Method =125211, DCM, Biplane Ellipse
LVIDd(M)	29436-3, LN, Left Ventricle Internal End Diastolic Dimension	ImageMode = G-0394, SRT, M Mode;

LVIDs(2D) 29438-9, LN, Left Vd

LVIDd(M) 29436-3, LN, Left Ventricle Internal End Diastolic Dimension ImageMode = G-0394, SRT, M Mode; Method =125206, DCM, Cube Method



M7 Series Diagnostic Ultrasound System

FS(Teich-2D)	18051-3, LN, Left Ventricular Fractional Shortening	ImageMode = G-03A2, SRT, 2D mode; Method =125209, DCM, Teichholz
FS(Gibson-2D)	18051-3, LN, Left Ventricular Fractional Shortening	ImageMode = G-03A2, SRT, 2D mode; Method =VM12228-03, MRUS, Gibson
IVSd(2D)	18154-5, LN, Interventricular Septum Diastolic Thickness	ImageMode = G-03A2, SRT, 2D mode;
IVSd(LV Mass Cube-2D)	18154-5, LN, Interventricular Septum Diastolic Thickness	ImageMode = G-03A2, SRT, 2D mode;
IVSd(LV Mass Cube-M)	18154-5, LN, Interventricular Septum Diastolic Thickness	ImageMode = G-0394, SRT, M Mode; Method =125221, DCM, Left Ventricle Mass by M-mode
IVSd(M)	18154-5, LN, Interventricular Septum Diastolic Thickness	ImageMode = G-0394, SRT, M Mode; Method =
IVSd Teich(2D)	18154-5, LN, Interventricular Septum Diastolic Thickness	ImageMode = G-03A2, SRT, 2D mode; Method =125209, DCM, Teichholz
IVSd Teich(M)	18154-5, LN, Interventricular Septum Diastolic Thickness	ImageMode = G-0394, SRT, M Mode; Method =125209, DCM, Teichholz
IVSd Cube(2D)	18154-5, LN, Interventricular Septum Diastolic Thickness	ImageMode = G-03A2, SRT, 2D mode; Method =125206, DCM, Cube Method
IVSd Cube(M)	18154-5, LN, Interventricular Septum Diastolic Thickness	ImageMode = G-0394, SRT, M Mode; Method =125206, DCM, Cube Method
IVSd Gibson(2D)	18154-5, LN, Interventricular Septum Diastolic Thickness	ImageMode = G-03A2, SRT, 2D mode; Method =VM12228-03, MRUS, Gibson
IVSd Gibson(M)	18154-5, LN, Interventricular Septum Diastolic Thickness	ImageMode = G-0394, SRT, M Mode; Method =VM12228-03, MRUS, Gibson
IVSd/LVPWd(2D)	18155-2, LN, Interventricular Septum to Posterior Wall Thickness Ratio	CardiacCyclePoint =F-32011, SRT, End Diastole; ImageMode = G-03A2, SRT, 2D mode;
IVSs/LVPWs(2D)	18155-2, LN, Interventricular Septum to Posterior Wall Thickness Ratio	CardiacCyclePoint =109070, SRT, End Systole; ImageMode = G-03A2, SRT, 2D mode;
IVSd/LVPWd(M)	18155-2, LN, Interventricular Septum to Posterior Wall Thickness Ratio	CardiacCyclePoint =F-32011, SRT, End Diastole; ImageMode = G-0394, SRT, M Mode;
IVSs/LVPWs(M)	18155-2, LN, Interventricular Septum to Posterior Wall Thickness Ratio	CardiacCyclePoint =109070, SRT, End Systole; ImageMode = G-0394, SRT, M Mode;
IVS%(2D)	18054-7, LN, Interventricular Septum % Thickening	ImageMode = G-03A2, SRT, 2D mode;
IVS%(M)	18054-7, LN, Interventricular Septum % Thickening	ImageMode = G-0394, SRT, M Mode;
IVSs(2D)	18158-6, LN, Interventricular Septum Systolic Thickness	ImageMode = G-03A2, SRT, 2D mode;

IVSs(M)	18158-6, LN, Interventricular Septum Systolic Thickness	ImageMode = G-0394, SRT, M Mode;
IVSs Teich(2D)	18158-6, LN, Interventricular Septum Systolic Thickness	ImageMode = G-03A2, SRT, 2D mode; Method =125209, DCM, Teichholz
IVSs Teich(M)	18158-6, LN, Interventricular Septum Systolic Thickness	ImageMode = G-0394, SRT, M Mode; Method =125209, DCM, Teichholz
IVSs Cube(2D)	18158-6, LN, Interventricular Septum Systolic Thickness	ImageMode = G-03A2, SRT, 2D mode; Method =125206, DCM, Cube Method
IVSs Cube(M)	18158-6, LN, Interventricular Septum Systolic Thickness	ImageMode = G-0394, SRT, M Mode; Method =125206, DCM, Cube Method
IVSs Gibson(2D)	18158-6, LN, Interventricular Septum Systolic Thickness	ImageMode = G-03A2, SRT, 2D mode; Method =VM12228-03, MRUS, Gibson
IVSs Gibson(M)	18158-6, LN, Interventricular Septum Systolic Thickness	ImageMode = G-0394, SRT, M Mode; Method =VM12228-03, MRUS, Gibson
LVPW%(2D)	18053-9, LN, Left Ventricle Posterior Wall % Thickening	ImageMode = G-03A2, SRT, 2D mode;
LVPW%(M)	18053-9, LN, Left Ventricle Posterior Wall % Thickening	ImageMode = G-0394, SRT, M Mode;
LVLd apical(Mod.Simpson)	18077-8, LN, Left Ventricle diastolic major axis	ImageMode = G-03A2, SRT, 2D mode; Method =VM12228-02, MRUS, Method of Disks, Simpson
LVLd(A2C)	18077-8, LN, Left Ventricle diastolic major axis	ImageMode = G-03A2, SRT, 2D mode; ImageView = G-A19B, SRT, Apical two chamber; Method =125208, DCM, Method of Disks, Single Plane
LVLd(A4C)	18077-8, LN, Left Ventricle diastolic major axis	ImageMode = G-03A2, SRT, 2D mode; ImageView = G-A19C, SRT, Apical four chamber; Method =125208, DCM, Method of Disks, Single Plane
LVLd apical(SP Ellipse)	18077-8, LN, Left Ventricle diastolic major axis	ImageMode = G-03A2, SRT, 2D mode; Method =125226, DCM, Single Plane Ellipse
LVLd apical(Bullet)	18077-8, LN, Left Ventricle diastolic major axis	ImageMode = G-03A2, SRT, 2D mode; Method =VM12228-01, MRUS, Bullet
LVLd apical(LV Mass A-L)	18077-8, LN, Left Ventricle diastolic major axis	ImageMode = G-03A2, SRT, 2D mode; Method =125205, DCM, Area-Length Single Plane
LVLd2i	18077-8, LN, Left Ventricle diastolic major axis	ImageMode = G-03A2, SRT, 2D mode; ImageView = G-A19B, SRT, Apical two chamber; Method =125207, DCM, Method of Disks, Biplane

LVLd4i	18077-8, LN, Left Ventricle diastolic major axis	ImageMode = G-03A2, SRT, 2D mode; ImageView = G-A19C, SRT, Apical four chamber; Method =125207, DCM, Method of Disks, Biplane
LVLs apical(Mod.Simpson)	18076-0, LN, Left Ventricle systolic major axis	ImageMode = G-03A2, SRT, 2D mode;
LVLs(A2C)	18076-0, LN, Left Ventricle systolic major axis	ImageMode = G-03A2, SRT, 2D mode; ImageView = G-A19B, SRT, Apical two chamber; Method =125226, DCM, Single Plane Ellipse
LVLs(A4C)	18076-0, LN, Left Ventricle systolic major axis	ImageMode = G-03A2, SRT, 2D mode; ImageView = G-A19C, SRT, Apical four chamber; Method =125226, DCM, Single Plane Ellipse
LVLs apical(SP Ellipse)	18076-0, LN, Left Ventricle systolic major axis	ImageMode = G-03A2, SRT, 2D mode;
LVLs apical(Bullet)	18076-0, LN, Left Ventricle systolic major axis	ImageMode = G-03A2, SRT, 2D mode;
LVLs2i	18076-0, LN, Left Ventricle systolic major axis	ImageMode = G-03A2, SRT, 2D mode; ImageView = G-A19B, SRT, Apical two chamber; Method =125207, DCM, Method of Disks, Biplane
LVLs4i	18076-0, LN, Left Ventricle systolic major axis	ImageMode = G-03A2, SRT, 2D mode; ImageView = G-A19C, SRT, Apical four chamber; Method =125207, DCM, Method of Disks, Biplane
LVPWs(2D)	18156-0, LN, Left Ventricle Posterior Wall Systolic Thickness	ImageMode = G-03A2, SRT, 2D mode;
LVPWs(M)	18156-0, LN, Left Ventricle Posterior Wall Systolic Thickness	ImageMode = G-0394, SRT, M Mode;
LVPWs Cube(2D)	18156-0, LN, Left Ventricle Posterior Wall Systolic Thickness	ImageMode = G-03A2, SRT, 2D mode; Method =125206, DCM, Cube Method
LVPWs Cube(M)	18156-0, LN, Left Ventricle Posterior Wall Systolic Thickness	ImageMode = G-0394, SRT, M Mode; Method =125206, DCM, Cube Method
LVPWs Teich(2D)	18156-0, LN, Left Ventricle Posterior Wall Systolic Thickness	ImageMode = G-03A2, SRT, 2D mode; Method =125209, DCM, Teichholz
LVPWs Teich(M)	18156-0, LN, Left Ventricle Posterior Wall Systolic Thickness	ImageMode = G-0394, SRT, M Mode; Method =125209, DCM, Teichholz
LVPWs Gibson(2D)	18156-0, LN, Left Ventricle Posterior Wall Systolic Thickness	ImageMode = G-03A2, SRT, 2D mode; Method =VM12228-03, MRUS, Gibson

LVPWs Gibson(M)	18156-0, LN, Left Ventricle Posterior Wall Systolic Thickness	ImageMode = G-0394, SRT, M Mode; Method = VM12228-03, MRUS, Gibson
LVPWd(2D)	18152-9, LN, Left Ventricle Posterior Wall Diastolic Thickness	ImageMode = G-03A2, SRT, 2D mode;
LVPWd(LV Mass-2D)	18152-9, LN, Left Ventricle Posterior Wall Diastolic Thickness	ImageMode = G-03A2, SRT, 2D mode;
LVPWd(LV Mass-M)	18152-9, LN, Left Ventricle Posterior Wall Diastolic Thickness	ImageMode = G-0394, SRT, M Mode; Method = 125221, DCM, Left Ventricle Mass by M-mode
LVPWd(M)	18152-9, LN, Left Ventricle Posterior Wall Diastolic Thickness	ImageMode = G-0394, SRT, M Mode;
LVPWd Cube(2D)	18152-9, LN, Left Ventricle Posterior Wall Diastolic Thickness	ImageMode = G-03A2, SRT, 2D mode; Method = 125206, DCM, Cube Method
LVPWd Cube(M)	18152-9, LN, Left Ventricle Posterior Wall Diastolic Thickness	ImageMode = G-0394, SRT, M Mode; Method = 125206, DCM, Cube Method
LVPWd Teich(2D)	18152-9, LN, Left Ventricle Posterior Wall Diastolic Thickness	ImageMode = G-03A2, SRT, 2D mode; Method = 125209, DCM, Teichholz
LVPWd Teich(M)	18152-9, LN, Left Ventricle Posterior Wall Diastolic Thickness	ImageMode = G-0394, SRT, M Mode; Method = 125209, DCM, Teichholz
LVPWd Gibson(2D)	18152-9, LN, Left Ventricle Posterior Wall Diastolic Thickness	ImageMode = G-03A2, SRT, 2D mode; Method = VM12228-03, MRUS, Gibson
LVPWd Gibson(M)	18152-9, LN, Left Ventricle Posterior Wall Diastolic Thickness	ImageMode = G-0394, SRT, M Mode; Method = VM12228-03, MRUS, Gibson
LV Major	M12201-01, MRUS, Left ventricular Major	ImageMode = G-03A2, SRT, 2D mode;
LV Minor	M12201-02, MRUS, Left ventricular Minor	ImageMode = G-03A2, SRT, 2D mode;
MVCF(Cube-M)	C12201-01, MRUS, Mean Velocity of Circumferential Fiber Shortening	ImageMode = G-0394, SRT, M Mode; Method = 125206, DCM, Cube Method
MVCF(Teich-M)	C12201-01, MRUS, Mean Velocity of Circumferential Fiber Shortening	ImageMode = G-0394, SRT, M Mode; Method = 125209, DCM, Teichholz
MVCF(Gibson-M)	C12201-01, MRUS, Mean Velocity of Circumferential Fiber Shortening	ImageMode = G-0394, SRT, M Mode; Method = VM12228-03, MRUS, Gibson
MVCF(Cube-2D)	C12201-01, MRUS, Mean Velocity of Circumferential Fiber Shortening	ImageMode = G-03A2, SRT, 2D mode; Method = 125206, DCM, Cube Method
MVCF(Teich-2D)	C12201-01, MRUS, Mean Velocity of Circumferential Fiber Shortening	ImageMode = G-03A2, SRT, 2D mode; Method = 125209, DCM, Teichholz
MVCF(Gibson-2D)	C12201-01, MRUS, Mean Velocity of Circumferential Fiber Shortening	ImageMode = G-03A2, SRT, 2D mode; Method = VM12228-03, MRUS, Gibson
a	M12201-03, MRUS, A Distance	ImageMode = G-03A2, SRT, 2D mode;
d	M12201-04, MRUS, B Distance	ImageMode = G-03A2, SRT, 2D mode;

LVIDd Index(M)	M12201-05,MRUS,Left ventricular internal diameter to BSA Ratio	CardiacCyclePoint =F-32011,SRT,End Diastole; ImageMode = G-0394,SRT,M Mode;
LVIDs Index(M)	M12201-05,MRUS,Left ventricular internal diameter to BSA Ratio	CardiacCyclePoint =109070,SRT,End Systole; ImageMode = G-0394,SRT,M Mode;
LVIDd Index(2D)	M12201-05,MRUS,Left ventricular internal diameter to BSA Ratio	CardiacCyclePoint =F-32011,SRT,End Diastole; ImageMode = G-03A2,SRT,2D mode;
LVIDs Index(2D)	M12201-05,MRUS,Left ventricular internal diameter to BSA Ratio	CardiacCyclePoint =109070,SRT,End Systole; ImageMode = G-03A2,SRT,2D mode;
rd2i	M12222-06,MRUS,Flow Radius	CardiacCyclePoint =F-32011,SRT,End Diastole; ImageMode = G-03A2,SRT,2D mode; ImageView = G-A19B,SRT,Apical two chamber; Method =125207,DCM,Method of Disks, Biplane
rd4i	M12222-06,MRUS,Flow Radius	CardiacCyclePoint =F-32011,SRT,End Diastole; ImageMode = G-03A2,SRT,2D mode; ImageView = G-A19C,SRT,Apical four chamber; Method =125207,DCM,Method of Disks, Biplane
rs2i	M12222-06,MRUS,Flow Radius	CardiacCyclePoint =109070,SRT,End Systole; ImageMode = G-03A2,SRT,2D mode; ImageView = G-A19B,SRT,Apical two chamber; Method =125207,DCM,Method of Disks, Biplane
rs4i	M12222-06,MRUS,Flow Radius	CardiacCyclePoint =109070,SRT,End Systole; ImageMode = G-03A2,SRT,2D mode; ImageView = G-A19C,SRT,Apical four chamber; Method =125207,DCM,Method of Disks, Biplane
LV Area(s)	G-0374,SRT,Left Ventricular Systolic Area	ImageMode = G-03A2,SRT,2D mode;
LVA _s apical(SP Ellipse)	G-0374,SRT,Left Ventricular Systolic Area	ImageMode = G-03A2,SRT,2D mode; ImageView = G-0395,SRT,Apical long axis;
LVA _s sax MV(Mod.Simpson)	G-0374,SRT,Left Ventricular Systolic Area	ImageMode =G-03A2,SRT,2D mode; ImageView = G-039A,SRT,Parasternal short axis at the Mitral Valve level;
LVA _s sax PM	G-0374,SRT,Left Ventricular Systolic Area	ImageMode =G-03A2,SRT,2D mode; ImageView = G-039B,SRT,Parasternal short axis at the Papillary Muscle level;
LVA _s (A2C)	G-0374,SRT,Left Ventricular Systolic Area	ImageMode =G-03A2,SRT,2D mode; ImageView = G-A19B,SRT,Apical two chamber; Method =125208,DCM,Method of Disks, Single Plane

LVA(A4C)	G-0374,SRT,Left Ventricular Systolic Area	ImageMode =G-03A2,SRT,2D mode; ImageView = G-A19C,SRT,Apical four chamber; Method =125208,DCM,Method of Disks, Single Plane
LVA sax MV(BP Ellipse)	G-0374,SRT,Left Ventricular Systolic Area	ImageMode =G-03A2,SRT,2D mode; ImageView = G-039A,SRT,Parasternal short axis at the Mitral Valve level; Method =125211,DCM,Biplane Ellipse
LVA sax MV(Bullet)	G-0374,SRT,Left Ventricular Systolic Area	ImageMode =G-03A2,SRT,2D mode; ImageView = G-039A,SRT,Parasternal short axis at the Mitral Valve level; Method =VM12228-01,MRUS,Bullet
LVA apical(BP Ellipse)	G-0374,SRT,Left Ventricular Systolic Area	ImageMode =G-03A2,SRT,2D mode; Method =125211,DCM,Biplane Ellipse
LV Area(d)	G-0375,SRT,Left Ventricular Diastolic Area	ImageMode =G-03A2,SRT,2D mode;
LVAd apical(SP Ellipse)	G-0375,SRT,Left Ventricular Diastolic Area	ImageMode =G-03A2,SRT,2D mode; ImageView = G-0395,SRT,Apical long axis;
LVAd sax MV(Mod.Simpson)	G-0375,SRT,Left Ventricular Diastolic Area	ImageMode =G-03A2,SRT,2D mode; ImageView = G-039A,SRT,Parasternal short axis at the Mitral Valve level;
LVAd sax PM	G-0375,SRT,Left Ventricular Diastolic Area	ImageMode =G-03A2,SRT,2D mode; ImageView = G-039B,SRT,Parasternal short axis at the Papillary Muscle level;
LVAd(A2C)	G-0375,SRT,Left Ventricular Diastolic Area	ImageMode =G-03A2,SRT,2D mode; ImageView = G-A19B,SRT,Apical two chamber; Method =125208,DCM,Method of Disks, Single Plane
LVAd(A4C)	G-0375,SRT,Left Ventricular Diastolic Area	ImageMode =G-03A2,SRT,2D mode; ImageView = G-A19C,SRT,Apical four chamber; Method =125208,DCM,Method of Disks, Single Plane
LVAd sax MV(BP Ellipse)	G-0375,SRT,Left Ventricular Diastolic Area	ImageMode =G-03A2,SRT,2D mode; ImageView = G-039A,SRT,Parasternal short axis at the Mitral Valve level; Method =125211,DCM,Biplane Ellipse
LVAd sax MV(Bullet)	G-0375,SRT,Left Ventricular Diastolic Area	ImageMode =G-03A2,SRT,2D mode; ImageView = G-039A,SRT,Parasternal short axis at the Mitral Valve level; Method =VM12228-01,MRUS,Bullet

LVAd apical(BP Ellipse)	G-0375,SRT,Left Ventricular Diastolic Area	ImageMode =G-03A2,SRT,2D mode; ImageView = G-0395,SRT,Apical long axis; Method =125211,DCM,Biplane Ellipse
LVAd sax Epi(LV Mass T-E)	G-0379,SRT,Left Ventricle Epicardial Diastolic Area, psax pap view	ImageMode =G-03A2,SRT,2D mode; ImageView = G-039B,SRT,Parasternal short axis at the Papillary Muscle level; Method =125222,DCM,Left Ventricle Mass by Truncated Ellipse
LVAd sax Epi(LV Mass A-L)	G-0379,SRT,Left Ventricle Epicardial Diastolic Area, psax pap view	ImageMode =G-03A2,SRT,2D mode; ImageView = G-039B,SRT,Parasternal short axis at the Papillary Muscle level; Method =125205,DCM,Area-Length Single Plane
LVAd sax Endo(LV Mass T-E)	M12240-01,MRUS,Left Ventricle Endocardiac Diastolic Area, psax pap view	ImageMode =G-03A2,SRT,2D mode; ImageView = G-039B,SRT,Parasternal short axis at the Papillary Muscle level; Method =125222,DCM,Left Ventricle Mass by Truncated Ellipse
LVAd sax Endo(LV Mass A-L)	M12240-01,MRUS,Left Ventricle Endocardiac Diastolic Area, psax pap view	ImageMode =G-03A2,SRT,2D mode; ImageView = G-039B,SRT,Parasternal short axis at the Papillary Muscle level; Method =125205,DCM,Area-Length Single Plane
EDV(SP Ellipse)	18026-5,LN,Left Ventricular End Diastolic Volume	ImageMode =G-03A2,SRT,2D mode; Method =125226,DCM,Single Plane Ellipse
EDV(BP Ellipse)	18026-5,LN,Left Ventricular End Diastolic Volume	ImageMode =G-03A2,SRT,2D mode; Method =125211,DCM,Biplane Ellipse
EDV(Bullet)	18026-5,LN,Left Ventricular End Diastolic Volume	ImageMode =G-03A2,SRT,2D mode; Method =VM12228-01,MRUS,Bullet
EDV(Mod.Simpson)	18026-5,LN,Left Ventricular End Diastolic Volume	ImageMode =G-03A2,SRT,2D mode; Method =VM12228-02,MRUS,Method of Disks,Simpson
EDV(Simp SP-A2C)	18026-5,LN,Left Ventricular End Diastolic Volume	ImageMode =G-03A2,SRT,2D mode; ImageView = G-A19B,SRT,Apical two chamber; Method =125208,DCM,Method of Disks, Single Plane
EDV(Simpson BP)	18026-5,LN,Left Ventricular End Diastolic Volume	ImageMode =G-03A2,SRT,2D mode; Method =125207,DCM,Method of Disks, Biplane
EDV(Simp BP-A2C)	18026-5,LN,Left Ventricular End Diastolic Volume	ImageMode =G-03A2,SRT,2D mode; ImageView = G-A19B,SRT,Apical two chamber; Method =125207,DCM,Method of Disks, Biplane



M7 Series Diagnostic Ultrasound System

EDV(Simp BP-A4C)	18026-5,LN,Left Ventricular End Diastolic Volume	ImageMode =G-03A2,SRT,2D mode; ImageView = G-A19C,SRT,Apical four chamber; Method =125207,DCM,Method of Disks, Biplane
EDV(Cube-M)	18026-5,LN,Left Ventricular End Diastolic Volume	ImageMode =G-0394,SRT,M Mode; Method =125206,DCM,Cube Method
EDV(Teich-M)	18026-5,LN,Left Ventricular End Diastolic Volume	ImageMode =G-0394,SRT,M Mode; Method =125209,DCM,Teichholz
EDV(Gibson-M)	18026-5,LN,Left Ventricular End Diastolic Volume	ImageMode =G-0394,SRT,M Mode; Method =VM12228-03,MRUS,Gibson
EDV(Cube-2D)	18026-5,LN,Left Ventricular End Diastolic Volume	ImageMode =G-03A2,SRT,2D mode; Method =125206,DCM,Cube Method
EDV(Teich-2D)	18026-5,LN,Left Ventricular End Diastolic Volume	ImageMode =G-03A2,SRT,2D mode; Method =125209,DCM,Teichholz
EDV(Gibson-2D)	18026-5,LN,Left Ventricular End Diastolic Volume	ImageMode =G-03A2,SRT,2D mode; Method =VM12228-03,MRUS,Gibson
EDV(Simp SP-A4C)	18026-5,LN,Left Ventricular End Diastolic Volume	ImageMode =G-03A2,SRT,2D mode; ImageView = G-A19C,SRT,Apical four chamber; Method =125208,DCM,Method of Disks, Single Plane
ESV(SP Ellipse)	18148-7,LN,Left Ventricular End Systolic Volume	ImageMode =G-03A2,SRT,2D mode; Method =125226,DCM,Single Plane Ellipse
ESV(BP Ellipse)	18148-7,LN,Left Ventricular End Systolic Volume	ImageMode =G-03A2,SRT,2D mode; Method =125211,DCM,Biplane Ellipse
ESV(Bullet)	18148-7,LN,Left Ventricular End Systolic Volume	ImageMode =G-03A2,SRT,2D mode; Method =VM12228-01,MRUS,Bullet
ESV(Mod.Simpson)	18148-7,LN,Left Ventricular End Systolic Volume	ImageMode =G-03A2,SRT,2D mode; Method =VM12228-02,MRUS,Method of Disks,Simpson
ESV(Simp SP-A2C)	18148-7,LN,Left Ventricular End Systolic Volume	ImageMode =G-03A2,SRT,2D mode; ImageView = G-A19B,SRT,Apical two chamber; Method =125208,DCM,Method of Disks, Single Plane
ESV(Simpson BP)	18148-7,LN,Left Ventricular End Systolic Volume	ImageMode =G-03A2,SRT,2D mode; Method =125207,DCM,Method of Disks, Biplane
ESV(Simp BP-A2C)	18148-7,LN,Left Ventricular End Systolic Volume	ImageMode =G-03A2,SRT,2D mode; ImageView = G-A19B,SRT,Apical two chamber; Method =125207,DCM,Method of Disks, Biplane

ESV(Simp BP-A4C)	18148-7,LN,Left Ventricular End Systolic Volume	ImageMode =G-03A2,SRT,2D mode; ImageView = G-A19C,SRT,Apical four chamber; Method =125207,DCM,Method of Disks, Biplane
ESV(Cube-M)	18148-7,LN,Left Ventricular End Systolic Volume	ImageMode =G-0394,SRT,M Mode; Method =125206,DCM,Cube Method
ESV(Teich-M)	18148-7,LN,Left Ventricular End Systolic Volume	ImageMode =G-0394,SRT,M Mode; Method =125209,DCM,Teichholz
ESV(Gibson-M)	18148-7,LN,Left Ventricular End Systolic Volume	ImageMode =G-0394,SRT,M Mode; Method =VM12228-03,MRUS,Gibson
ESV(Cube-2D)	18148-7,LN,Left Ventricular End Systolic Volume	ImageMode =G-03A2,SRT,2D mode; Method =125206,DCM,Cube Method
ESV(Teich-2D)	18148-7,LN,Left Ventricular End Systolic Volume	ImageMode =G-03A2,SRT,2D mode; Method =125209,DCM,Teichholz
ESV(Gibson-2D)	18148-7,LN,Left Ventricular End Systolic Volume	ImageMode =G-03A2,SRT,2D mode; Method =VM12228-03,MRUS,Gibson
ESV(Simp SP-A4C)	18148-7,LN,Left Ventricular End Systolic Volume	ImageMode =G-03A2,SRT,2D mode; ImageView = G-A19C,SRT,Apical four chamber; Method =125208,DCM,Method of Disks, Single Plane
EF(SP Ellipse)	18043-0,LN,Left Ventricular Ejection Fraction	ImageMode =G-03A2,SRT,2D mode; Method =125226,DCM,Single Plane Ellipse
EF(BP Ellipse)	18043-0,LN,Left Ventricular Ejection Fraction	ImageMode =G-03A2,SRT,2D mode; Method =125211,DCM,Biplane Ellipse
EF(Bullet)	18043-0,LN,Left Ventricular Ejection Fraction	ImageMode =G-03A2,SRT,2D mode; Method =VM12228-01,MRUS,Bullet
EF(Mod.Simpson)	18043-0,LN,Left Ventricular Ejection Fraction	ImageMode =G-03A2,SRT,2D mode; Method =VM12228-02,MRUS,Method of Disks,Simpson
EF(A2C)	18043-0,LN,Left Ventricular Ejection Fraction	ImageMode =G-03A2,SRT,2D mode; Method =125208,DCM,Method of Disks, Single Plane
EF(Simpson BP)	18043-0,LN,Left Ventricular Ejection Fraction	ImageMode =G-03A2,SRT,2D mode; Method =125207,DCM,Method of Disks, Biplane
EF2(Simpson BP)	18043-0,LN,Left Ventricular Ejection Fraction	ImageMode =G-03A2,SRT,2D mode; ImageView = G-A19B,SRT,Apical two chamber; Method =125207,DCM,Method of Disks, Biplane

EF4(Simpson BP)	18043-0,LN,Left Ventricular Ejection Fraction	ImageMode =G-03A2,SRT,2D mode; ImageView = G-A19C,SRT,Apical four chamber; Method =125207,DCM,Method of Disks, Biplane
EF(Cube-M)	18043-0,LN,Left Ventricular Ejection Fraction	ImageMode =G-0394,SRT,M Mode; Method =125206,DCM,Cube Method
EF(Teich-M)	18043-0,LN,Left Ventricular Ejection Fraction	ImageMode =G-0394,SRT,M Mode; Method =125209,DCM,Teichholz
EF(Gibson-M)	18043-0,LN,Left Ventricular Ejection Fraction	ImageMode =G-0394,SRT,M Mode; Method =VM12228-03,MRUS,Gibson
EF(Cube-2D)	18043-0,LN,Left Ventricular Ejection Fraction	ImageMode =G-03A2,SRT,2D mode; Method =125206,DCM,Cube Method
EF(Teich-2D)	18043-0,LN,Left Ventricular Ejection Fraction	ImageMode =G-03A2,SRT,2D mode; Method =125209,DCM,Teichholz
EF(Gibson-2D)	18043-0,LN,Left Ventricular Ejection Fraction	ImageMode =G-03A2,SRT,2D mode; Method =VM12228-03,MRUS,Gibson
EF(A4C)	18043-0,LN,Left Ventricular Ejection Fraction	ImageMode =G-03A2,SRT,2D mode; ImageView = G-A19C,SRT,Apical four chamber; Method =125208,DCM,Method of Disks, Single Plane
LVOT Area	G-038E,SRT,Cardiovascular Orifice Area	ImageMode =G-03A2,SRT,2D mode;
LVOT Diam(2D)	G-038F,SRT,Cardiovascular Orifice Diameter	ImageMode =G-03A2,SRT,2D mode;
LVOT Diam(M)	G-038F,SRT,Cardiovascular Orifice Diameter	ImageMode =G-0394,SRT,M Mode;
LVOT Diam(MVA VTI)	G-038F,SRT,Cardiovascular Orifice Diameter	ImageMode =G-03A2,SRT,2D mode;
LVOT Diam(AVA VTI)	G-038F,SRT,Cardiovascular Orifice Diameter	ImageMode =G-03A2,SRT,2D mode;
LVOT Diam(AVA Vmax)	G-038F,SRT,Cardiovascular Orifice Diameter	ImageMode =G-03A2,SRT,2D mode;
LVOT Vmax	11726-7,LN,Peak Velocity	
LVOT Vmax(LVOT VTI)	11726-7,LN,Peak Velocity	
LVOT Vmean	20352-1,LN,Mean Velocity	
LVOT PGmax	20247-3,LN,Peak Gradient	
LVOT PGmax(LVOT VTI)	20247-3,LN,Peak Gradient	
LVOT PGmean	20256-4,LN,Mean Gradient	



M7 Series Diagnostic Ultrasound System

LVOT VTI	20354-7,LN,Velocity Time Integral	
LVOT VTI(MVA VTI)	20354-7,LN,Velocity Time Integral	
LVOT VTI(AVA VTI)	20354-7,LN,Velocity Time Integral	
LVOT AccT	20168-1,LN,Acceleration Time	
LVOT θ	M12222-01,MRUS, Angle	
LVOT Acc Slope	M12222-02,MRUS, Acceleration Slope	
LV Mass(Cube-M)	18087-7,LN,Left Ventricle Mass	ImageMode =G-0394,SRT,M Mode; Method =125221,DCM,Left Ventricle Mass by M-mode
LV Mass(T-E)	18087-7,LN,Left Ventricle Mass	ImageMode =G-03A2,SRT,2D mode; Method =125222,DCM,Left Ventricle Mass by Truncated Ellipse
LV Mass(A-L)	18087-7,LN,Left Ventricle Mass	ImageMode =G-03A2,SRT,2D mode; Method =125205,DCM,Area-Length Single Plane
LV Mass(Cube-2D)	18087-7,LN,Left Ventricle Mass	ImageMode =G-03A2,SRT,2D mode;
IVRT	18071-1,LN,Left Ventricular Isovolumic Relaxation Time	
IVCT	G-037E,SRT,Left Ventricular Isovolumic Contraction Time	
LVIMP(M)	G-037F,SRT,Left Ventricular Index of Myocardial Performance	ImageMode =G-0394,SRT,M Mode;
LVIMP(Doppler)	G-037F,SRT,Left Ventricular Index of Myocardial Performance	
LVPEP(M)	M12203-01,MRUS,Left Ventricle Pre-Ejection Period	ImageMode =G-0394,SRT,M Mode;
LVPEP(Doppler)	M12203-01,MRUS,Left Ventricle Pre-Ejection Period	
LVET(M)	M12203-02,MRUS,Left Ventricle Ejection Time	ImageMode =G-0394,SRT,M Mode;
LVET(Doppler)	M12203-02,MRUS,Left Ventricle Ejection Time	
LVET LVIMP(M)	M12203-02,MRUS,Left Ventricle Ejection Time	ImageMode =G-0394,SRT,M Mode;
LVET LVIMP(Doppler)	M12203-02,MRUS,Left Ventricle Ejection Time	

LV Mass-I(Cube-M)	C12203-01,MRUS,Left ventricular Mass Weight Index	ImageMode =G-0394,SRT,M Mode; Method =125221,DCM,Left Ventricle Mass by M-mode
LV Mass-I(T-E)	C12203-01,MRUS,Left ventricular Mass Weight Index	ImageMode =G-03A2,SRT,2D mode; Method =125222,DCM,Left Ventricle Mass by Truncated Ellipse
LV Mass-I(A-L)	C12203-01,MRUS,Left ventricular Mass Weight Index	ImageMode =G-03A2,SRT,2D mode; Method =125205,DCM,Area-Length Single Plane
LV Mass-I(Cube-2D)	C12203-01,MRUS,Left ventricular Mass Weight Index	ImageMode =G-03A2,SRT,2D mode;
LVPEP/ET(M)	C12203-02,MRUS,Left Ventricle Pre-Ejection Period to Ejection Time Ratio	ImageMode =G-0394,SRT,M Mode;
LVPEP/ET(Doppler)	C12203-02,MRUS,Left Ventricle Pre-Ejection Period to Ejection Time Ratio	
LVOT SV	F-32120,SRT,Stroke Volume	
SV(SP Ellipse)	F-32120,SRT,Stroke Volume	ImageMode =G-03A2,SRT,2D mode; Method =125226,DCM,Single Plane Ellipse
SV(BP Ellipse)	F-32120,SRT,Stroke Volume	ImageMode =G-03A2,SRT,2D mode; Method =125211,DCM,Biplane Ellipse
SV(Bullet)	F-32120,SRT,Stroke Volume	ImageMode =G-03A2,SRT,2D mode; Method =VM12228-01,MRUS,Bullet
SV(Mod.Simpson)	F-32120,SRT,Stroke Volume	ImageMode =G-03A2,SRT,2D mode; Method =VM12228-02,MRUS,Method of Disks,Simpson
SV(A2C)	F-32120,SRT,Stroke Volume	ImageMode = G-03A2,SRT,2D mode; Method =125208,DCM,Method of Disks, Single Plane
SV(Simpson BP)	F-32120,SRT,Stroke Volume	ImageMode = G-03A2,SRT,2D mode; Method =125207,DCM,Method of Disks, Biplane
SV2(Simpson BP)	F-32120,SRT,Stroke Volume	ImageMode = G-03A2,SRT,2D mode; ImageView = G-A19B,SRT,Apical two chamber; Method =125207,DCM,Method of Disks, Biplane
SV4(Simpson BP)	F-32120,SRT,Stroke Volume	ImageMode = G-03A2,SRT,2D mode; ImageView = G-A19C,SRT,Apical four chamber; Method =125207,DCM,Method of Disks, Biplane

SV(Cube-M)	F-32120,SRT,Stroke Volume	ImageMode = G-0394,SRT,M Mode; Method =125206,DCM,Cube Method
SV(Teich-M)	F-32120,SRT,Stroke Volume	ImageMode = G-0394,SRT,M Mode; Method =125209,DCM,Teichholz
SV(Gibson-M)	F-32120,SRT,Stroke Volume	ImageMode = G-0394,SRT,M Mode; Method =VM12228-03,MRUS,Gibson
SV(Cube-2D)	F-32120,SRT,Stroke Volume	ImageMode = G-03A2,SRT,2D mode; Method =125206,DCM,Cube Method
SV(Teich-2D)	F-32120,SRT,Stroke Volume	ImageMode = G-03A2,SRT,2D mode; Method =125209,DCM,Teichholz
SV(Gibson-2D)	F-32120,SRT,Stroke Volume	ImageMode = G-03A2,SRT,2D mode; Method =VM12228-03,MRUS,Gibson
SV(A4C)	F-32120,SRT,Stroke Volume	ImageMode = G-03A2,SRT,2D mode; ImageView = G-A19C,SRT,Apical four chamber; Method =125208,DCM,Method of Disks, Single Plane
LVOT CO	F-32100,SRT,Cardiac Output	
CO(SP Ellipse)	F-32100,SRT,Cardiac Output	ImageMode = G-03A2,SRT,2D mode; Method =125226,DCM,Single Plane Ellipse
CO(BP Ellipse)	F-32100,SRT,Cardiac Output	ImageMode = G-03A2,SRT,2D mode; Method =125211,DCM,Biplane Ellipse
CO(Bullet)	F-32100,SRT,Cardiac Output	ImageMode = G-03A2,SRT,2D mode; Method =VM12228-01,MRUS,Bullet
CO(Mod.Simpson)	F-32100,SRT,Cardiac Output	ImageMode = G-03A2,SRT,2D mode; Method =VM12228-02,MRUS,Method of Disks,Simpson
CO(A2C)	F-32100,SRT,Cardiac Output	ImageMode = G-03A2,SRT,2D mode; Method =125208,DCM,Method of Disks, Single Plane
CO(Simpson BP)	F-32100,SRT,Cardiac Output	ImageMode = G-03A2,SRT,2D mode; Method =125207,DCM,Method of Disks, Biplane
CO2(Simpson BP)	F-32100,SRT,Cardiac Output	ImageMode = G-03A2,SRT,2D mode; ImageView = G-A19B,SRT,Apical two chamber; Method =125207,DCM,Method of Disks, Biplane
CO4(Simpson BP)	F-32100,SRT,Cardiac Output	ImageMode = G-03A2,SRT,2D mode; ImageView = G-A19C,SRT,Apical four chamber; Method =125207,DCM,Method of Disks, Biplane

CO(Cube-M)	F-32100,SRT,Cardiac Output	ImageMode = G-0394,SRT,M Mode; Method =125206,DCM,Cube Method
CO(Teich-M)	F-32100,SRT,Cardiac Output	ImageMode = G-0394,SRT,M Mode; Method =125209,DCM,Teichholz
CO(Gibson-M)	F-32100,SRT,Cardiac Output	ImageMode = G-0394,SRT,M Mode; Method =VM12228-03,MRUS,Gibson
CO(Cube-2D)	F-32100,SRT,Cardiac Output	ImageMode = G-03A2,SRT,2D mode; Method =125206,DCM,Cube Method
CO(Teich-2D)	F-32100,SRT,Cardiac Output	ImageMode = G-03A2,SRT,2D mode; Method =125209,DCM,Teichholz
CO(Gibson-2D)	F-32100,SRT,Cardiac Output	ImageMode = G-03A2,SRT,2D mode; Method =VM12228-03,MRUS,Gibson
CO(A4C)	F-32100,SRT,Cardiac Output	ImageMode = G-03A2,SRT,2D mode; ImageView = G-A19C,SRT,Apical four chamber; Method =125208,DCM,Method of Disks, Single Plane
LVOT CI	F-32110,SRT,Cardiac Index	
CI(SP Ellipse)	F-32110,SRT,Cardiac Index	ImageMode = G-03A2,SRT,2D mode; Method =125226,DCM,Single Plane Ellipse
CI(BP Ellipse)	F-32110,SRT,Cardiac Index	ImageMode = G-03A2,SRT,2D mode; Method =125211,DCM,Biplane Ellipse
CI(Bullet)	F-32110,SRT,Cardiac Index	ImageMode = G-03A2,SRT,2D mode; Method =VM12228-01,MRUS,Bullet
CI(Mod.Simpson)	F-32110,SRT,Cardiac Index	ImageMode = G-03A2,SRT,2D mode; Method =VM12228-02,MRUS,Method of Disks,Simpson
CI(A2C)	F-32110,SRT,Cardiac Index	ImageMode = G-03A2,SRT,2D mode; Method =125208,DCM,Method of Disks, Single Plane
CI(Simpson BP)	F-32110,SRT,Cardiac Index	ImageMode = G-03A2,SRT,2D mode; Method =125207,DCM,Method of Disks, Biplane
CI2(Simpson BP)	F-32110,SRT,Cardiac Index	ImageMode = G-03A2,SRT,2D mode; ImageView = G-A19B,SRT,Apical two chamber; Method =125207,DCM,Method of Disks, Biplane
CI4(Simpson BP)	F-32110,SRT,Cardiac Index	ImageMode = G-03A2,SRT,2D mode; ImageView = G-A19C,SRT,Apical four chamber; Method =125207,DCM,Method of Disks, Biplane

CI(Cube-M)	F-32110,SRT,Cardiac Index	ImageMode = G-0394,SRT,M Mode; Method =125206,DCM,Cube Method
CI(Teich-M)	F-32110,SRT,Cardiac Index	ImageMode = G-0394,SRT,M Mode; Method =125209,DCM,Teichholz
CI(Gibson-M)	F-32110,SRT,Cardiac Index	ImageMode = G-0394,SRT,M Mode; Method =VM12228-03,MRUS,Gibson
CI(Cube-2D)	F-32110,SRT,Cardiac Index	ImageMode = G-03A2,SRT,2D mode; Method =125206,DCM,Cube Method
CI(Teich-2D)	F-32110,SRT,Cardiac Index	ImageMode = G-03A2,SRT,2D mode; Method =125209,DCM,Teichholz
CI(Gibson-2D)	F-32110,SRT,Cardiac Index	ImageMode = G-03A2,SRT,2D mode; Method =VM12228-03,MRUS,Gibson
CI(A4C)	F-32110,SRT,Cardiac Index	ImageMode = G-03A2,SRT,2D mode; ImageView = G-A19C,SRT,Apical four chamber; Method =125208,DCM,Method of Disks, Single Plane
LVOT SI	F-00078,SRT,Stroke Index	
SI(SP Ellipse)	F-00078,SRT,Stroke Index	ImageMode = G-03A2,SRT,2D mode; Method =125226,DCM,Single Plane Ellipse
SI(BP Ellipse)	F-00078,SRT,Stroke Index	ImageMode = G-03A2,SRT,2D mode; Method =125211,DCM,Biplane Ellipse
SI(Bullet)	F-00078,SRT,Stroke Index	ImageMode = G-03A2,SRT,2D mode; Method =VM12228-01,MRUS,Bullet
SI(Mod.Simpson)	F-00078,SRT,Stroke Index	ImageMode = G-03A2,SRT,2D mode; Method =VM12228-02,MRUS,Method of Disks,Simpson
SI(A2C)	F-00078,SRT,Stroke Index	ImageMode = G-03A2,SRT,2D mode; Method =125208,DCM,Method of Disks, Single Plane
SI(Simpson BP)	F-00078,SRT,Stroke Index	ImageMode = G-03A2,SRT,2D mode; Method =125207,DCM,Method of Disks, Biplane
SI2(Simpson BP)	F-00078,SRT,Stroke Index	ImageMode = G-03A2,SRT,2D mode; ImageView = G-A19B,SRT,Apical two chamber; Method =125207,DCM,Method of Disks, Biplane
SI4(Simpson BP)	F-00078,SRT,Stroke Index	ImageMode = G-03A2,SRT,2D mode; ImageView = G-A19C,SRT,Apical four chamber; Method =125207,DCM,Method of Disks, Biplane



M7 Series Diagnostic Ultrasound System

RV Minor	M12204-02,MRUS,Right ventricular Minor	ImageMode = G-03A2,SRT,2D mode;
RV Area(d)	M12204-03,MRUS,Right ventricular Area at end-diastole	ImageMode = G-03A2,SRT,2D mode;
RV Area(s)	M12204-04,MRUS,Right ventricular Area at end-systole	ImageMode = G-03A2,SRT,2D mode;
RVPEP(M)	M12204-05,MRUS,Right Ventricle Pre-Ejection Period	ImageMode = G-0394,SRT,M Mode;
RVPEP(Doppler)	M12204-05,MRUS,Right Ventricle Pre-Ejection Period	
RVET(M)	M12204-06,MRUS,Right Ventricle Ejection Time	ImageMode = G-0394,SRT,M Mode;
RVET(RVIMP)	M12204-06,MRUS,Right Ventricle Ejection Time	
RVET(Doppler)	M12204-06,MRUS,Right Ventricle Ejection Time	
RVPEP/ET(M)	C12204-01,MRUS,Right Ventricle Pre-Ejection Period to Ejection Time Ratio	ImageMode = G-0394,SRT,M Mode;
RVPEP/ET(Doppler)	C12204-01,MRUS,Right Ventricle Pre-Ejection Period to Ejection Time Ratio	
RVOT HR	8867-4,LN,Heart rate	
RVOT Diam(2D)	G-038F,SRT,Cardiovascular Orifice Diameter	ImageMode = G-03A2,SRT,2D mode;
RVOT Diam(M)	G-038F,SRT,Cardiovascular Orifice Diameter	ImageMode = G-0394,SRT,M Mode;
RVOT Vmax	11726-7,LN,Peak Velocity	
RVOT Vmax(RVOT VTI)	11726-7,LN,Peak Velocity	
RVOT Vmean	20352-1,LN,Mean Velocity	
RVOT PGmax	20247-3,LN,Peak Gradient	
RVOT PGmax(RVOT VTI)	20247-3,LN,Peak Gradient	
RVOT PGmean	20256-4,LN,Mean Gradient	
RVOT VTI	20354-7,LN,Velocity Time Integral	
RVOT θ	M12222-01,MRUS,Angle	

B.40.3. Left Atrium Measurements

<i>MODALITY Label</i>	<i>DICOM Mapping</i>	<i>Optional Modifiers</i>
LA Diam(2D)	29469-4,LN,Left Atrium Antero-posterior Systolic Dimension	ImageMode = G-03A2,SRT,2D mode;
LA Diam(M)	29469-4,LN,Left Atrium Antero-posterior Systolic Dimension	ImageMode = G-0394,SRT,M Mode;

LA Diam(LA Vol A-L)	29469-4, LN, Left Atrium Antero-posterior Systolic Dimension	ImageMode = G-03A2, SRT, 2D mode; Method = 125205, DCM, Area-Length Single Plane
LA Diam(LA/Ao-2D)	29469-4, LN, Left Atrium Antero-posterior Systolic Dimension	ImageMode = G-03A2, SRT, 2D mode;
LA Diam(LA/Ao-M)	29469-4, LN, Left Atrium Antero-posterior Systolic Dimension	ImageMode = G-0394, SRT, M Mode;
LA/Ao(2D)	17985-3, LN, Left Atrium to Aortic Root Ratio	ImageMode = G-03A2, SRT, 2D mode;
LA/Ao(M)	17985-3, LN, Left Atrium to Aortic Root Ratio	ImageMode = G-0394, SRT, M Mode;
LA Area	17977-0, LN, Left Atrium Systolic Area	ImageMode = G-03A2, SRT, 2D mode;
LAA(A2C)	17977-0, LN, Left Atrium Systolic Area	ImageMode = G-03A2, SRT, 2D mode; ImageView = G-A19B, SRT, Apical two chamber; Method = 125205, DCM, Area-Length Single Plane
LAA(A4C)	17977-0, LN, Left Atrium Systolic Area	ImageMode = G-03A2, SRT, 2D mode; ImageView = G-A19C, SRT, Apical four chamber; Method = 125205, DCM, Area-Length Single Plane
LA Vol(A-L)	G-0383, SRT, Left Atrium Systolic Volume	ImageMode = G-03A2, SRT, 2D mode; Method = 125205, DCM, Area-Length Single Plane
LA Vol(A2C)	G-0383, SRT, Left Atrium Systolic Volume	ImageMode = G-03A2, SRT, 2D mode; ImageView = G-A19B, SRT, Apical two chamber; Method = 125208, DCM, Method of Disks, Single Plane
LA Vol(A4C)	G-0383, SRT, Left Atrium Systolic Volume	ImageMode = G-03A2, SRT, 2D mode; ImageView = G-A19C, SRT, Apical four chamber; Method = 125208, DCM, Method of Disks, Single Plane
LA Major	M12205-01, MRUS, Left atrium Major	ImageMode = G-03A2, SRT, 2D mode;
LA Minor	M12205-02, MRUS, Left atrium Minor	ImageMode = G-03A2, SRT, 2D mode;
LeftA.AR/LA.M	C12205-01, MRUS, Aortic Root to Left Atrium Ratio	

B.40.4. Right Atrium Measurements

<i>MODALITY Label</i>	<i>DICOM Mapping</i>	<i>Optional Modifiers</i>
-----------------------	----------------------	---------------------------

RAP	18070-3, LN, Right Atrium Systolic Pressure	
RA Area	17988-7, LN, Right Atrium Systolic Area	ImageMode = G-03A2, SRT, 2D mode;
RA Major	M12206-01, MRUS, Right atrium Major	ImageMode = G-03A2, SRT, 2D mode;
RA Minor	M12206-02, MRUS, Right atrium Minor	ImageMode = G-03A2, SRT, 2D mode;
RA Vol(A4C)	M12206-03, MRUS, Right atrium Volume	ImageMode = G-03A2, SRT, 2D mode; ImageView = G-A19C, SRT, Apical four chamber; Method = 125208, DCM, Method of Disks, Single Plane

B.40.5. Aortic Valve Measurements

<i>MODALITY Label</i>	<i>DICOM Mapping</i>	<i>Optional Modifiers</i>
ACS(2D)	17996-0, LN, Aortic Valve Cusp Separation	ImageMode = G-03A2, SRT, 2D mode;
ACS(M)	17996-0, LN, Aortic Valve Cusp Separation	ImageMode = G-0394, SRT, M Mode;
AV AccT/ET	G-0382, SRT, Ratio of Aortic Valve Acceleration Time to Ejection Time	
AV HR	8867-4, LN, Heart rate	
AR Flow	33878-0, LN, Volume Flow	Flow Direction =R-42E61, SRT, Regurgitant Flow; Method =125216, DCM, Proximal Isovelocity Surface Area
AR Flow Rate	34141-2, LN, Peak Instantaneous Flow Rate	Flow Direction =R-42E61, SRT, Regurgitant Flow; ImageMode = R-409E2, SRT, Doppler Color Flow; Method =125216, DCM, Proximal Isovelocity Surface Area
AVA	G-038E, SRT, Cardiovascular Orifice Area	Flow Direction =R-42047, SRT, Antegrade Flow; ImageMode = G-03A2, SRT, 2D mode; Method =125220, DCM, Planimetry
AVA(VTI)	G-038E, SRT, Cardiovascular Orifice Area	Flow Direction =R-42047, SRT, Antegrade Flow; Method =125215, DCM, Continuity Equation by Velocity Time Integral
AV Diam(2D)	G-038F, SRT, Cardiovascular Orifice Diameter	ImageMode = G-03A2, SRT, 2D mode;
AV Diam(Qp/Qs)	G-038F, SRT, Cardiovascular Orifice Diameter	ImageMode = G-03A2, SRT, 2D mode;
AR Fraction	G-0390, SRT, Regurgitant Fraction	Flow Direction =R-42E61, SRT, Regurgitant Flow; Method =125216, DCM, Proximal Isovelocity Surface Area





M7 Series Diagnostic Ultrasound System

AR Rad

M12222-06,MRUS,Flow Radius

Flow Direction = R-42E61,SRT,Regurgitant Flow;

ImageMode = R-409E2, SRT, Doppler Color Flow;

MV C-O dur(M)	G-0387,SRT,Mitral Valve Closure to Opening Time	ImageMode = G-0394,SRT,M Mode ;
MV C-O dur(Doppler)	G-0387,SRT,Mitral Valve Closure to Opening Time	
dP/dt	18035-6,LN,Mitral Regurgitation Dp/dt derived from Mitral Reg. velocity	Flow Direction =R-42E61,SRT,Regurgitant Flow;
MCS(2D)	M12207-01,MRUS,Mitral valve cusp separate distance	ImageMode = G-03A2,SRT,2D mode ;
MCS(M)	M12207-01,MRUS,Mitral valve cusp separate distance	ImageMode = G-0394,SRT,M Mode ;
MV D-E Slope	M12207-02,MRUS,Mitral Valve D-E Slope	ImageMode = G-0394,SRT,M Mode ;
MV A Amp	M12207-03,MRUS,Amplitude of the A wave	ImageMode = G-0394,SRT,M Mode ;
MV E Amp	M12207-04,MRUS,Amplitude of the E wave	ImageMode = G-0394,SRT,M Mode ;
MV DE	M12207-05,MRUS,Amplitude from D Point to E Point	ImageMode = G-0394,SRT,M Mode ;
MV E PG	M12207-06,MRUS,Mitral Valve E-wave Pressure Gradient	
MV A PG	M12207-07,MRUS,Mitral Valve A-wave Pressure Gradient	
MV E VTI	M12207-08,MRUS,E wave Velocity Time Integral	Flow Direction =R-42047,SRT,Antegrade Flow;
MV A VTI	M12207-09,MRUS,A wave Velocity Time Integral	Flow Direction =R-42047,SRT,Antegrade Flow;
MV E Dur	M12207-10,MRUS,Mitral Valve E-Wave Duration	
Sa(medial)	M12207-11,MRUS,Systolic Velocity of the Mitral Annulus(medial)	ImageMode = IM12224-01,MRUS,Tissue Doppler Imaging;
Ea(medial)	M12207-12,MRUS,Early diastolic velocity of the mitral annulus(medial)	ImageMode = IM12224-01,MRUS,Tissue Doppler Imaging;
Aa(medial)	M12207-13,MRUS,Late diastolic velocity of the mitral annulus(medial)	ImageMode = IM12224-01,MRUS,Tissue Doppler Imaging;
Ea/Aa(medial)	M12207-14,MRUS,Early diastolic velocity to Late diastolic velocity Ratio	ImageMode = IM12224-01,MRUS,Tissue Doppler Imaging;
Ata(medial)	M12207-15,MRUS,Acceleration Time of Early diastolic velocity	ImageMode = IM12224-01,MRUS,Tissue Doppler Imaging;
Ara(medial)	M12207-16,MRUS,Acceleration Rate of Early diastolic velocity	ImageMode = IM12224-01,MRUS,Tissue Doppler Imaging;



M7 Series Diagnostic Ultrasound System

Dta(medial)	M12207-17,MRUS,Deceleration Time of Early diastolic velocity	ImageMode = IM12224-01,MRUS,Tissue Doppler Imaging;
Dra(medial)	M12207-18,MRUS,Deceleration Rate of Early diastolic velocity	ImageMode = IM12224-01,MRUS,Tissue Doppler Imaging;
Sa(lateral)	M12207-19,MRUS,Systolic Velocity of the Mitral Annulus(lateral)	ImageMode = IM12224-01,MRUS,Tissue Doppler Imaging;
Ea(lateral)	M12207-20,MRUS,Early diastolic velocity of the mitral annulus(lateral)	ImageMode = IM12224-01,MRUS,Tissue Doppler Imaging;
Aa(lateral)	M12207-21,MRUS,Late diastolic velocity of the mitral annulus(lateral)	ImageMode = IM12224-01,MRUS,Tissue Doppler Imaging;
Ea/Aa(lateral)	M12207-22,MRUS,Early diastolic velocity to Late diastolic velocity Ratio	ImageMode = IM12224-01,MRUS,Tissue Doppler Imaging;
Ata(lateral)	M12207-23,MRUS,Acceleration Time of Early diastolic velocity	ImageMode = IM12224-01,MRUS,Tissue Doppler Imaging;
Ara(lateral)	M12207-24,MRUS,Acceleration Rate of Early diastolic velocity	ImageMode = IM12224-01,MRUS,Tissue Doppler Imaging;
Dta(lateral)	M12207-25,MRUS,Deceleration Time of Early diastolic velocity	ImageMode = IM12224-01,MRUS,Tissue Doppler Imaging;
Dra(lateral)	M12207-26,MRUS,Deceleration Rate of Early diastolic velocity	ImageMode = IM12224-01,MRUS,Tissue Doppler Imaging;
MS Rad	M12207-27,MRUS,Mitral Stenosis Radius	ImageMode = R-409E2, SRT, Doppler Color Flow; Method = 125216,DCM,Proximal Isovelocity Surface Area
MS Als.Vel	M12207-28,MRUS,Mitral Stenosis Aliasing Velocity	ImageMode = R-409E2, SRT, Doppler Color Flow; Method = 125216,DCM,Proximal Isovelocity Surface Area
MS Vmax	M12207-29,MRUS,Mitral Stenosis Maximum Velocity	
MS Vmax(PISA MS)	M12207-29,MRUS,Mitral Stenosis Maximum Velocity	Method = 125216,DCM,Proximal Isovelocity Surface Area

MS Area	M12207-30,MRUS,Mitral Stenosis Area	Method = 125216,DCM,Proximal Isovelocity Surface Area
MS P _{gmax}	C12207-01,MRUS,Mitral Stenosis Maximum Pressure Gradient	
MV HR	8867-4,LN,Heart rate	
MR Flow	33878-0,LN,Volume Flow	Flow Direction =R-42E61,SRT,Regurgitant Flow; Method = 125216,DCM,Proximal Isovelocity Surface Area
MR Flow Rate	34141-2,LN,Peak Instantaneous Flow Rate	Flow Direction =R-42E61,SRT,Regurgitant Flow; ImageMode = R-409E2, SRT, Doppler Color Flow; Method = 125216,DCM,Proximal Isovelocity Surface Area
MVA	G-038E,SRT,Cardiovascular Orifice Area	Flow Direction =R-42047,SRT,Antegrade Flow; ImageMode = G-03A2,SRT,2D mode; Method = 125220,DCM,Planimetry
MVA(PHT)	G-038E,SRT,Cardiovascular Orifice Area	Flow Direction =R-42047,SRT,Antegrade Flow; Method = 125210,DCM,Area by Pressure Half-Time
MVA(VTI)	G-038E,SRT,Cardiovascular Orifice Area	Flow Direction =R-42047,SRT,Antegrade Flow; Method = 125215,DCM,Continuity Equation by Velocity Time Integral
MV Diam	G-038F,SRT,Cardiovascular Orifice Diameter	Flow Direction =R-42047,SRT,Antegrade Flow; ImageMode = G-03A2,SRT,2D mode;
MR Fraction	G-0390,SRT,Regurgitant Fraction	Flow Direction =R-42E61,SRT,Regurgitant Flow; Method = 125216,DCM,Proximal Isovelocity Surface Area
MV V _{max}	11726-7,LN,Peak Velocity	Flow Direction =R-42047,SRT, Antegrade Flow;
MR V _{max}	11726-7,LN,Peak Velocity	Flow Direction =R-42E61,SRT,Regurgitant Flow; ImageMode = G-03A2,SRT,2D mode;



M7 Series Diagnostic Ultrasound System



M7 Series Diagnostic Ultrasound System

PV Diam(Qp/Qs)	G-038F,SRT,Cardiovascular Orifice Diameter	Flow Direction =R-42047,SRT,Antegrade Flow; ImageMode = G-03A2,SRT,2D mode;
PR Fraction	G-0390,SRT,Regurgitant Fraction	Flow Direction =R-42E61,SRT,Regurgitant Flow; Method = 125216,DCM,Proximal Isovelocity Surface Area
PR Ved	11653-3,LN,End Diastolic Velocity	Flow Direction =R-42E61,SRT,Regurgitant Flow;
PR Ved(PAEDP)	11653-3,LN,End Diastolic Velocity	Flow Direction =R-42E61,SRT,Regurgitant Flow;
PV Vmax	11726-7,LN,Peak Velocity	Flow Direction =R-42047,SRT, Antegrade Flow;
PR Vmax	11726-7,LN,Peak Velocity	Flow Direction =R-42E61,SRT,Regurgitant Flow;
PV Vmax(PV VTI)	11726-7,LN,Peak Velocity	Flow Direction =R-42047,SRT, Antegrade Flow;
PR Vmax(PR VTI)	11726-7,LN,Peak Velocity	Flow Direction =R-42E61,SRT,Regurgitant Flow;
PR Vmax(PR PHT)	11726-7,LN,Peak Velocity	Flow Direction =R-42E61,SRT,Regurgitant Flow;
PR Vmax(PISA PR)	11726-7,LN,Peak Velocity	Flow Direction =R-42E61,SRT,Regurgitant Flow;
PV Vmean	20352-1,LN,Mean Velocity	Flow Direction =R-42047,SRT, Antegrade Flow;
PR Vmean	20352-1,LN,Mean Velocity	Flow Direction =R-42E61,SRT,Regurgitant Flow;
PV PGmax	20247-3,LN,Peak Gradient	Flow Direction =R-42047,SRT,Antegrade Flow;
PR PGmax	20247-3,LN,Peak Gradient	Flow Direction =R-42E61,SRT,Regurgitant Flow;
PV PGmax(PV VTI)	20247-3,LN,Peak Gradient	Flow Direction =R-42047,SRT, Antegrade Flow;
PR PGmax(PR VTI)	20247-3,LN,Peak Gradient	Flow Direction =R-42E61,SRT,Regurgitant Flow;





M7 Series Diagnostic Ultrasound System

TVA	G-038E,SRT,Cardiovascular Orifice Area	Flow Direction =R-42047,SRT, Antegrade Flow; ImageMode = G-03A2,SRT,2D mode; Method = 125220,DCM,Planimetry
TVA(PHT)	G-038E,SRT,Cardiovascular Orifice Area	Flow Direction =R-42047,SRT, Antegrade Flow; Method = 125210,DCM,Area by Pressure Half-Time
TV Diam	G-038F,SRT,Cardiovascular Orifice Diameter	Flow Direction =R-42047,SRT, Antegrade Flow; ImageMode = G-03A2,SRT,2D mode;
TR Fraction	G-0390,SRT,Regurgitant Fraction	Flow Direction =R-42E61,SRT,Regurgitant Flow; Method = 125216,DCM,Proximal Isovelocity Surface Area
TV Vmax	11726-7,LN,Peak Velocity	Flow Direction =R-42047,SRT, Antegrade Flow;
TR Vmax	11726-7,LN,Peak Velocity	Flow Direction =R-42E61,SRT,Regurgitant Flow;
TV Vmax(TV PHT)	11726-7,LN,Peak Velocity	Flow Direction =R-42047,SRT, Antegrade Flow;
TV Vmax(TV VTI)	11726-7,LN,Peak Velocity	Flow Direction =R-42047,SRT, Antegrade Flow;
TR Vmax(TR VTI)	11726-7,LN,Peak Velocity	Flow Direction =R-42E61,SRT,Regurgitant Flow;
TR Vmax(PISA TR)	11726-7,LN,Peak Velocity	Flow Direction =R-42E61,SRT,Regurgitant Flow; Method = 125216,DCM,Proximal Isovelocity Surface Area
TR Vmax(RVSP)	11726-7,LN,Peak Velocity	Flow Direction =R-42E61,SRT,Regurgitant Flow;
TV Vmean	20352-1,LN,Mean Velocity	Flow Direction =R-42047,SRT, Antegrade Flow;
TR Vmean	20352-1,LN,Mean Velocity	Flow Direction =R-42E61,SRT,Regurgitant Flow;
TV PGmax(TV PHT)	20247-3,LN,Peak Gradient	Flow Direction =R-42047,SRT, Antegrade Flow;
TV PGmax(TV VTI)	20247-3,LN,Peak Gradient	Flow Direction =R-42047,SRT, Antegrade Flow;
TV PGmax	20247-3,LN,Peak Gradient	Flow Direction =R-42047,SRT, Antegrade Flow;
TR PGmax	20247-3,LN,Peak Gradient	Flow Direction =R-42E61,SRT,Regurgitant Flow;
TR PGmax(TR VTI)	20247-3,LN,Peak Gradient	Flow Direction =R-42E61,SRT,Regurgitant Flow;
TR PGmax(RVSP)	20247-3,LN,Peak Gradient	Flow Direction =R-42E61,SRT,Regurgitant Flow;
TV PGmean	20256-4,LN,Mean Gradient	Flow Direction =R-42047,SRT, Antegrade Flow;
TR PGmean	20256-4,LN,Mean Gradient	Flow Direction =R-42E61,SRT,Regurgitant Flow;
TV VTI	20354-7,LN,Velocity Time Integral	Flow Direction =R-42047,SRT, Antegrade Flow;
TR VTI	20354-7,LN,Velocity Time Integral	Flow Direction =R-42E61,SRT,Regurgitant Flow;
TR VTI(PISA TR)	20354-7,LN,Velocity Time Integral	Flow Direction =R-42E61,SRT,Regurgitant Flow; Method =125216,DCM,Proximal Isovelocity Surface Area
TV PHT	20280-4,LN,Pressure Half-Time	Flow Direction =R-42E61,SRT,Regurgitant Flow;
TV AccT	20168-1,LN,Acceleration Time	Flow Direction =R-42047,SRT, Antegrade Flow;

TV DecT	20217-6, LN, Deceleration Time	Flow Direction =R-42E61, SRT, Regurgitant Flow;
TV Dec Slope	20216-8, LN, Deceleration Slope	Flow Direction =R-42E61, SRT, Regurgitant Flow;
TV A Dur	M12208-01, MRUS, Tricuspid Valve E-Wave Duration	Flow Direction =R-42047, SRT, Antegrade Flow;
TV E PG	M12208-02, MRUS, Tricuspid Valve E Wave Pressure Gradient	Flow Direction =R-42047, SRT, Antegrade Flow;
TV A PG	M12208-03, MRUS, Tricuspid Valve A Wave Pressure Gradient	Flow Direction =R-42047, SRT, Antegrade Flow;
TV Acc Slope	M12222-02, MRUS, Acceleration Slope	Flow Direction =R-42047, SRT, Antegrade Flow;
TV AccT/DecT	M12222-07, MRUS, Acceleration Time/Deceleration Time	Flow Direction =R-42047, SRT, Antegrade Flow;
TR Rad	M12222-06, MRUS, Flow Radius	Flow Direction =R-42E61, SRT, Regurgitant Flow; ImageMode = R-409E2, SRT, Doppler Color Flow;
TR Als.Vel	M12222-02, MRUS, Aliasing Velocity	ImageMode = R-409E2, SRT, Doppler Color Flow;
TV SV	F-32120, SRT, Stroke Volume	
TV CO	F-32100, SRT, Cardiac Output	
TV CI	F-32110, SRT, Cardiac Index	
TV SI	F-00078, SRT, Stroke Index	
PISA	M12222-09, MRUS, Effective Regurgitant Orifice Area	

B.40.9. Aorta Measurements

<i>MODALITY Label</i>	<i>DICOM Mapping</i>	<i>Optional Modifiers</i>
Ao Diam(2D)	18015-8, LN, Aortic Root Diameter	ImageMode = G-03A2, SRT, 2D mode;
Ao Diam(M)	18015-8, LN, Aortic Root Diameter	ImageMode = G-0394, SRT, M Mode;
Ao Diam(LA/Ao-2D)	18015-8, LN, Aortic Root Diameter	ImageMode = G-03A2, SRT, 2D mode;
Ao Diam(LA/Ao-M)	18015-8, LN, Aortic Root Diameter	ImageMode = G-0394, SRT, M Mode;
Ao Arch Diam(2D)	18011-7, LN, Aortic Arch Diameter	ImageMode = G-03A2, SRT, 2D mode;

Ao Desc Diam(2D)	18013-3, LN, Descending Aortic Diameter	ImageMode = G-03A2, SRT, 2D mode;
Ao Desc Diam(M)	18013-3, LN, Descending Aortic Diameter	ImageMode = G-0394, SRT, M Mode;
Ao st junct(2D)	M12212-01, MRUS, Aortic Sinotubular junction Diameter	ImageMode = G-03A2, SRT, 2D mode;
Ao st junct(M)	M12212-01, MRUS, Aortic Sinotubular junction Diameter	ImageMode = G-0394, SRT, M Mode;
Ao Sinus Diam(2D)	M12212-02, MRUS, Aortic Sinus Diameter	ImageMode = G-03A2, SRT, 2D mode;
Ao Sinus Diam(M)	M12212-02, MRUS, Aortic Sinus Diameter	ImageMode = G-0394, SRT, M Mode;
Duct Art Diam	M12212-03, MRUS, Ductus Artery Diameter	ImageMode = G-03A2, SRT, 2D mode;
Pre Ductal	M12212-04, MRUS, Previous Ductal Diameter	ImageMode = G-03A2, SRT, 2D mode;
LCA	M12212-05, MRUS, Left Coronary Artery Diameter	ImageMode = G-03A2, SRT, 2D mode;
RCA	M12212-06, MRUS, Right Coronary Artery Diameter	ImageMode = G-03A2, SRT, 2D mode;
AAo Vmax	11726-7, LN, Peak Velocity	
DAo Vmax	11726-7, LN, Peak Velocity	
AAo PGmax	20247-3, LN, Peak Gradient	
DAo PGmax	20247-3, LN, Peak Gradient	

B.40.10. Pulmonary Artery Measurements

<i>MODALITY Label</i>	<i>DICOM Mapping</i>	<i>Optional Modifiers</i>
MPA Diam(2D)	18020-8, LN, Main Pulmonary Artery Diameter	ImageMode =G-03A2, SRT, 2D mode;
MPA Diam(M)	18020-8, LN, Main Pulmonary Artery Diameter	ImageMode =G-0394, SRT, M Mode;
RPA Diam(2D)	18021-6, LN, Right Pulmonary Artery Diameter	ImageMode =G-03A2, SRT, 2D mode;
RPA Diam(M)	18021-6, LN, Right Pulmonary Artery Diameter	ImageMode =G-0394, SRT, M Mode;
LPA Diam(2D)	18019-0, LN, Left Pulmonary Artery Diameter	ImageMode =G-03A2, SRT, 2D mode;
LPA Diam(M)	18019-0, LN, Left Pulmonary Artery Diameter	ImageMode =G-0394, SRT, M Mode;
MPA Vmax	G-038A, SRT, Main Pulmonary Artery Peak Velocity	
Post Ductal	M12210-01, MRUS, Posterior ductal Diameter	ImageMode =G-03A2, SRT, 2D mode;
PAEDP	C12210-01, MRUS, Pulmonary Artery End Diastolic Pressure	
LPA Vmax	11726-7, LN, Peak Velocity	
RPA Vmax	11726-7, LN, Peak Velocity	
MPA PGmax	20247-3, LN, Peak Gradient	
LPA PGmax	20247-3, LN, Peak Gradient	
RPA PGmax	20247-3, LN, Peak Gradient	

B.40.11. Vena Cava Measurements

<i>MODALITY Label</i>	<i>DICOM Mapping</i>	<i>Optional Modifiers</i>
IVC Diam(Insp)	18006-7, LN, Inferior Vena Cava Diameter	RespiratoryCyclePoint=F-20010, SRT, During Inspiration; ImageMode =G-03A2, SRT, 2D mode;
IVC Diam(Expir)	18006-7, LN, Inferior Vena Cava Diameter	RespiratoryCyclePoint=F-20020, SRT, During Expiration; ImageMode =G-03A2, SRT, 2D mode;
SVC Diam(Insp)	M12215-01, MRUS, Superior Vena Cava Diameter	RespiratoryCyclePoint=F-20010, SRT, During Inspiration; ImageMode =G-03A2, SRT, 2D mode;
SVC Diam(Expir)	M12215-01, MRUS, Superior Vena Cava Diameter	RespiratoryCyclePoint=F-20020, SRT, During Expiration; ImageMode =G-03A2, SRT, 2D mode;
IVC Vel(Insp)	M12215-02, MRUS, Inferior Vena Cava Velocity	RespiratoryCyclePoint=F-20010, SRT, During Inspiration;
IVC Vel(Expir)	M12215-02, MRUS, Inferior Vena Cava Velocity	RespiratoryCyclePoint=F-20020, SRT, During Expiration;
SVC Vel(Insp)	M12215-03, MRUS, Superior Vena Cava Velocity	RespiratoryCyclePoint=F-20010, SRT, During Inspiration;
SVC Vel(Expir)	M12215-03, MRUS, Superior Vena Cava Velocity	Re(e)10.9125(s)0.714619(p)-7.75872(i)-5.74612(r)4.45178(a)10.9125



PVein D Vel	M12214-02,MRUS,Pulmonary Vein D-wave flow Velocity	
PVein A Vel	M12214-03,MRUS,Pulmonary Vein A-wave flow Velocity	
PVein DecT	M12214-04,MRUS,Pulmonary Vein Deceleration Time	
PVein S/D	M12214-05,MRUS,Pulmonary Vein Ratio of S-Wave velocity to D-wave velocity	
PVein SF	M12214-06,MRUS,Pulmonary Vein Systolic fraction	

B.40.13. Cardiac Shunt Study Measurements

<i>MODALITY Label</i>	<i>DICOM Mapping</i>	<i>Optional Modifiers</i>
Qp/Qs	29462-9,LN,Pulmonary-to-Systemic Shunt Flow Ratio	
Qp-Qs	M12217-01,MRUS,Pulmonary-sub-Systemic Shunt Flow Difference	
PV HR(Qp/Qs)	8867-4,LN,Heart rate	
AV HR(Qp/Qs)	8867-4,LN,Heart rate	
PV SV(Qp/Qs)	F-32120,SRT,Stroke Volume	
PV CO(Qp/Qs)	F-32100,SRT,Cardiac Output	
AV SV(Qp/Qs)	F-32120,SRT,Stroke Volume	
AV CO(Qp/Qs)	F-32100,SRT,Cardiac Output	

B.40.14. Congenital Anomaly of Cardiovascular System Measurements

<i>MODALITY Label</i>	<i>DICOM Mapping</i>	<i>Optional Modifiers</i>
PDA Diam	M12218-01,MRUS,Patent Ductus Arteriosus DiameRU	

C. Appendix : Vascular structured reporting template

This appendix lists the DICOM Structured Report (SR) mappings used in the Vascular Structured Reports of ultrasound system SR files.

The mappings are organized in a manner similar to the DICOM SR Templates as described in PS 3.16 of the DICOM Standard. The Vascular Report mappings follow the DICOM SR Template TID 5100: Vascular Ultrasound Procedure Report, except where noted.

All private code values use the Coding Scheme Designator "MRUS".

C.1. TID (5100) Vascular Ultrasound Report

This is the template for the root the content tree for the vascular ultrasound procedure report.

	NL	Rel with Parent	VT	Concept Name	Used in MODALITY	Value Set Constraint	Comment
1			CONTAINER	EV (125100, DCM, "Vascular Ultrasound Procedure Report")	✓		
2	>	HAS OBS CONTEXT	CODE	EV (R-40FB8, SRT, "Temporal periods Relating to Procedure")		DCID (12102) Temporal Periods Relating To Procedure or Therapy	

3 > HAS INCL UDE DTID (1204) Language (t)-5.746135(e)10.91n1.4T*[(M)-78.9-()2556458(N)5.16458(C)ref 7un(t)-5.746 CONCEPT MOD



M7 Series Diagnostic Ultrasound System

9	>	CONTAINS	INCLUDE	DTID (5103) Vascular Ultrasound Section	✓	\$SectionScope = DT (T-40501, SRT, "Blood Vessel of Head") \$SectionLaterality = EV (G-A101, SRT, "Left") \$Anatomy = DCID (12105) Intracranial Cerebral Vessels	
1 0	>	CONTAINS	INCLUDE	DTID (5103) Vascular Ultrasound Section	✓	\$SectionScope = DT (T-40501, SRT, "Blood Vessel of Head") \$SectionLaterality = EV (G-A100, SRT, "Right") \$Anatomy = DCID (12105) Intracranial Cerebral Vessels	
1 1	>	CONTAINS	INCLUDE	DTID (5103) Vascular Ultrasound Section	✓	\$SectionScope = DT (T-40501, SRT, "Blood Vessel of Head") \$SectionLaterality = EV (G-A103, SRT, "Unilateral") \$Anatomy = DCID (12106) Intracranial Cerebral Vessels (unilateral)	
1 2	>	CONTAINS	INCLUDE	DTID (5103) Vascular Ultrasound Section	✓	\$SectionScope = DT (T-45005, SRT, "Artery of neck") \$SectionLaterality = EV (G-A101, SRT, "Left") \$Anatomy = DCID (12104) Extracranial Arteries \$AnatomyRatio = DCID (12123) Carotid Ratios	



M7 Series Diagnostic Ultrasound System

1 3	>	CONTAINS	INCLUDE	DTID (5103) Vascular Ultrasound Section	✓	<p>\$SectionScope = DT (T-45005, SRT, "Artery of neck")</p> <p>\$SectionLaterality = EV (G-A100, SRT, "Right")</p> <p>\$Anatomy = DCID (12104) Extracranial Arteries</p> <p>\$AnatomyRatio = DCID (12123) Carotid Ratios</p>
1 4	>	CONTAINS	INCLUDE	DTID (5103) Vascular Ultrasound Section	✓	<p>\$SectionScope = DT (T-47040, SRT, "Artery of Lower Extremity")</p> <p>\$SectionLaterality = EV (G-A101, SRT, "Left")</p> <p>\$Anatomy = DCID (12109) Lower Extremity Arteries</p> <p>\$AnatomyRatio = 8581-1, LN, Tibial/brachi al index</p>
1 5	>	CONTAINS	INCLUDE	DTID (5103) Vascular Ultrasound Section	✓	<p>\$SectionScope = DT (T-47040, SRT, "Artery of Lower Extremity")</p> <p>\$SectionLaterality = EV (G-A100, SRT, "Right")</p> <p>\$Anatomy = DCID (12109) Lower Extremity Arteries</p> <p>\$AnatomyRatio = 8581-1, LN, Tibial/brachi al index</p>
1 6	>	CONTAINS	INCLUDE	DTID (5103) Vascular Ultrasound Section	✓	<p>\$SectionScope = DT (T-49403, SRT, "Vein of Lower Extremity")</p> <p>\$SectionLaterality = EV (G-A101, SRT, "Left")</p> <p>\$Anatomy = DCID (12110) Lower Extremity Veins</p>



M7 Series Diagnostic Ultrasound System

17	>	CONTAINS	INCLUDE	DTID (5103) Vascular Ultrasound Section	✓	\$SectionScope = DT (T-49403, SRT, "Vein of Lower Extremity") \$SectionLaterality = EV (G-A100, SRT, "Right") \$Anatomy = DCID (12110) Lower Extremity Veins
18	>	CONTAINS	INCLUDE	DTID (5103) Vascular Ultrasound Section	✓	\$SectionScope = DT (T-47020, SRT, "Artery Of Upper Extremity") \$SectionLaterality = EV (G-A101, SRT, "Left") \$Anatomy = DCID (12107) Upper Extremity Arteries
19	>	CONTAINS	INCLUDE	DTID (5103) Vascular Ultrasound Section	✓	\$SectionScope = DT (T-47020, SRT, "Artery Of Upper Extremity") \$SectionLaterality = EV (G-A100, SRT, "Right") \$Anatomy = DCID (12107) Upper Extremity Arteries
20	>	CONTAINS	INCLUDE	DTID (5103) Vascular Ultrasound Section	✓	\$SectionScope = DT (T-47020, SRT, "Artery Of Upper Extremity") \$SectionLaterality = EV (G-A100, SRT, "Unilateral") \$Anatomy = DCID (SELCID-2) Upper Extremity Arteries(unilateral)



M7 Series Diagnostic Ultrasound System

2 1	>	CONTAINS	INCLUDE	DTID (5103) Vascular Ultrasound Section	✓	\$SectionScope = DT (T-49103, SRT, "Vein Of Upper Extremity") \$SectionLaterality = EV (G-A101, SRT, "Left") \$Anatomy = DCID (12108) Upper Extremity Veins	
2 2	>	CONTAINS	INCLUDE	DTID (5103) Vascular Ultrasound Section	✓	\$SectionScope = DT (T-49103, SRT, "Vein Of Upper Extremity") \$SectionLaterality = EV (G-A100, SRT, "Right") \$Anatomy = DCID (12108) Upper Extremity Veins	
2 3	>	CONTAINS	INCLUDE	DTID (5103) Vascular Ultrasound Section		\$SectionScope = DT (T-46002, SRT, "Artery of Abdomen") \$SectionLaterality = EV (G-A101, SRT, "Left") \$Anatomy = DCID (12111) Abdominal Arteries (lateral)	
2 4	>	CONTAINS	INCLUDE	DTID (5103) Vascular Ultrasound Section		\$SectionScope = DT (T-46002, SRT, "Artery of Abdomen") \$SectionLaterality = EV (G-A100, SRT, "Right") \$Anatomy = DCID (12111) Abdominal Arteries (lateral)	



M7 Series Diagnostic Ultrasound System

2 5	>	CONTAINS	INCLUDE	DTID (5103) Vascular Ultrasound Section	✓	\$SectionScope = DT (T-46002, SRT, "Artery of Abdomen") \$SectionLaterality = EV (G-A103, SRT, "Unilateral") \$Anatomy = DCID (12112) Abdominal Arteries (unilateral)	
2 6	>	CONTAINS	INCLUDE	DTID (5103) Vascular Ultrasound Section		\$SectionScope = DT (T-487A0, SRT, "Vein of Abdomen") \$SectionLaterality = EV (G-A101, SRT, "Left") \$Anatomy = DCID (12113) Abdominal Veins (lateral)	
2 7	>	CONTAINS	INCLUDE	DTID (5103) Vascular Ultrasound Section		\$SectionScope = DT (T-487A0, SRT, "Vein of Abdomen") \$SectionLaterality = EV (G-A100, SRT, "Right") \$Anatomy = DCID (12113) Abdominal Veins (lateral)	
2 8	>	CONTAINS	INCLUDE	DTID (5103) Vascular Ultrasound Section	✓	\$SectionScope = DT (T-487A0, SRT, " Vein of Abdomen") \$SectionLaterality = EV (G-A103, SRT, "Unilateral") \$Anatomy = DCID (12114) Abdominal Veins (unilateral)	



M7 Series Diagnostic Ultrasound System

29	>	CONTAINS	INCLUDE	DTID (5103) Vascular Ultrasound Section	✓	\$SectionScope = DT (T-71019, SRT, "Vascular Structure Of Kidney") \$SectionLaterality = EV (G-A101, SRT, "Left") \$Anatomy = DCID (12115) Renal Vessels	
30	>	CONTAINS	INCLUDE	DTID (5103) Vascular Ultrasound Section	✓	\$SectionScope = DT (T-71019, SRT, "Vascular Structure Of Kidney") \$SectionLaterality = EV (G-A100, SRT, "Right") \$Anatomy = DCID (12115) Renal Vessels	
31	>	CONTAINS	INCLUDE	DTID (5105) Ultrasound Graft Section			
32	>	CONTAINS	TEXT	(20121120,MRUS, "self-defined-measurementfile")			

C.2. TID (1001) Observation Context

This template specifies attributes of observation context that may be defined, extended or replaced at any location in the SR tree.

	NL	Rel with Parent	VT	Concept Name	Used in MODALITY	Value Set Constraint	Comment
1	>	HAS OBS CONTEXT	CODE	EV (121005,DCM, "Observer Type")	✓	(121006,DCM, "Person")	
2	>	HAS OBS CONTEXT	PNAME	EV (121008,DCM, "Person Observer Name")	✓	Operator from Info	
3	>	HAS OBS CONTEXT	TEXT	EV (121009,DCM, " Person Observer's Organization Name")	✓	Institution Name (0008,0080) of the General Equipment Module	



M7 Series Diagnostic Ultrasound System

4	>	HAS OBS CONTEXT	CODE	EV (121010,DCM, " Person Observer's Role in the Organization")	✓	(121093, DCM, "Sonographer")	
5	>	HAS OBS CONTEXT	CODE	EV (121024, DCM, "Subject Class")	✓	(121025, DCM, "Patient")	
6	>	HAS OBS CONTEXT	PNAME	EV (121029,DCM, "Subject Name")	✓	value of Patient's Name (0010,0010) in Patient Module	
7	>	HAS OBS CONTEXT	DATE	EV (121031,DCM, "Subject Birth Date")	✓	value of Patient's Birth Date (0010,0030) in Patient Module	
8	>	HAS OBS CONTEXT	CODE	EV (121032,DCM, "Subject Sex")	✓	value equivalent to Patient's Sex (0010,0040) in Patient Module	
9	>	HAS OBS CONTEXT	NUM	EV (121033,DCM, "Subject Age")	✓	value of Patient's Age (0010,1010) in Patient Study Module	

C.3. TID (5101) Vascular Patient Characteristics

	NL	Rel with Parent	VT	Concept Name	Used in MODALITY	Value Set Constraint	Comment
1			CONT AINER	EV (121118, DCM, "Patient Characteristics")			
2	>	CONTAINS	NUM	EV (121033, DCM, "Subject Age")	✓	Units = DCID (7456) Units of Measure for Age	
3	>	CONTAINS	CODE	EV (121032, DCM, "Subject Sex")	✓	DCID (7455) Sex	
4	>	CONTAINS	NUM	EV (8867-4, LN, "Heart Rate")			
5	>	CONTAINS	NUM	EV (F-008EC, SRT, "Systolic Blood Pressure")	✓		



M7 Series Diagnostic Ultrasound System

6	>	CONTAINS	NUM	EV (F-008ED, SRT, ✓ "Diastolic Blood Pressure")
---	---	----------	-----	---



M7 Series Diagnostic Ultrasound System

16	>>>	CONTAINS	TEXT	(G-A101,SNM3,Left)	✓		
17	>	CONTAINS	CONTAINER	(T-45160,SRT,Carotid Bifurcation)	✓		
18	>>	CONTAINS	CONTAINER	(FG3495-01, MRUS, Plaque Description)	✓		
19	>>>	CONTAINS	TEXT	(G-A100,SNM3,Right)	✓		
20	>>>	CONTAINS	TEXT	(G-A101,SNM3,Left)	✓		
21	>>	CONTAINS	CONTAINER	(FG3495-02, MRUS, Plaque Area)	✓		
22	>>>	CONTAINS	TEXT	(G-A100,SNM3,Right)	✓		
23	>>>	CONTAINS	TEXT	(G-A101,SNM3,Left)	✓		
24	>	CONTAINS	CONTAINER	(T-45300, SRT, Internal Carotid Artery)	✓		ICA
25	>>	CONTAINS	CONTAINER	(FG3495-01, MRUS, Plaque Description)	✓		
26	>>>	CONTAINS	TEXT	(G-A100,SNM3,Right)	✓		
27	>>>	CONTAINS	TEXT	(G-A101,SNM3,Left)	✓		
28	>>	CONTAINS	CONTAINER	(FG3495-02, MRUS, Plaque Area)	✓		
29	>>>	CONTAINS	TEXT	(G-A100,SNM3,Right)	✓		
30	>>>	CONTAINS	TEXT	(G-A101,SNM3,Left)	✓		
31	>	CONTAINS	CONTAINER	(T-45200,SRT,External Carotid Artery)	✓		ECA
32	>>	CONTAINS	CONTAINER	(FG3495-01, MRUS, Plaque Description)	✓		
33	>>>	CONTAINS	TEXT	(G-A100,SNM3,Right)	✓		
34	>>>	CONTAINS	TEXT	(G-A101,SNM3,Left)	✓		
35	>>	CONTAINS	CONTAINER	(FG3495-02, MRUS, Plaque Area)	✓		
36	>>>	CONTAINS	TEXT	(G-A100,SNM3,Right)	✓		
37	>>>	CONTAINS	TEXT	(G-A101,SNM3,Left)	✓		
38	>	CONTAINS	CONTAINER	(T-45700 ,SRT ,Vertebral Artery)	✓		
39	>>	CONTAINS	TEXT	(G-A100,SNM3,Right)	✓		
40	>>	CONTAINS	TEXT	(G-A101,SNM3,Left)	✓		
41	>	CONTAINS	CONTAINER	(T-46100,SRT,Subclavian	✓		



M7 Series Diagnostic Ultrasound System

				Artery)			
42	>>	CONTAINS	TEXT	(G-A100,SNM3,Right)	✓		
43	>>	CONTAINS	TEXT	(G-A101,SNM3,Left)	✓		
44	>	CONTAINS	TEXT	(T-46010,SRT,Brachiocephalic trunk)	✓		

C.5. TID (5103) Vascular Ultrasound Section

	NL	Rel with Parent	VT	Concept Name	Used in MODALITY	Value Set Constraint	Comment
1			CONTAINER	DT (121070, DCM, "Findings")	✓		
2	>	HAS CONCEPT MOD	CODE	EV (G-C0E3, SRT, "Finding Site")	✓	\$SectionScope	
3	>	HAS CONCEPT MOD	CODE	EV (G-C171, SRT, "Laterality")	✓	\$SectionLaterality	
4	>	CONTAINS	INCLUDE	DTID (5104) Vascular Measurement Group	✓	\$AnatomyGroup = \$Anatomy= DCID (12105) Intracranial Cerebral Vessels	
5	>	CONTAINS	INCLUDE	DTID (300) Measurement	✓	\$Measurement = \$AnatomyRatio	Only for Artery of neck

C.6. TID (5104) Vascular Ultrasound Measurement Group

	NL	Rel with Parent	VT	Concept Name	Used in MODALITY	Value Set Constraint	Comment
1			CONTAINER	\$AnatomyGroup			
2	>	HAS CONCEPT MOD	CODE	EV (G-A1F8, SRT, "Topographical		DCID (12116) Vessel Segment Modifiers	



M7 Series Diagnostic Ultrasound System

				Modifier")			
3	>	HAS CONCEPT MOD	CODE	EV (125101, DCM, "Vessel Branch")		DCID (12117) Vessel Branch Modifiers	
4	>	CONTAINS	INCLUDE	DTID (300) Measurement		\$Measurement = DCID (12119) Vascular Ultrasound Property \$Derivation = DCID (3627) Measurement Type	
5	>>	HAS CONCEPT MOD	CODE	EV (R-4089A, SRT, "Cardiac Cycle Point")		DCID (12233) Cardiac Phase	
6	>>	HAS CONCEPT MOD	CODE	EV (R-41FFC, SRT, "Temporal period related to eating")		DT (G-A491, SRT, "Post-prandial")	

C.7. CID (12104) Extracranial Arteries

CSD	CV	Code Meaning
SRT	T-45170	Carotid Bulb
SRT	T-45100	Common Carotid Artery
SRT	T-45200	External Carotid Artery
SRT	T-45300	Internal Carotid Artery
SRT	T-46100	Subclavian Artery
SRT	T-45700	Vertebral Artery

C.8. CID (12105) Intracranial Cerebral Vessels

CSD	CV	Code Meaning
SRT	T-45540	Anterior Cerebral Artery
SRT	T-45600	Middle Cerebral Artery
SRT	T-45900	Posterior Cerebral Artery
SRT	T-45320	Posterior Communicating Artery

C.9. CID (12106) Intracranial Cerebral Vessels (unilateral)

CSD	CV	Code Meaning
SRT	T-45800	Basilar Artery
SRT	T-45530	Anterior Communicating Artery
MRUS	V12106-01	Basilar Vein

C.10. CID (12107) Upper Extremity Arteries

CSD	CV	Code Meaning
SRT	T-47100	Axillary Artery
SRT	T-47160	Brachial Artery
SRT	T-47300	Radial Artery
SRT	T-46100	Subclavian Artery
SRT	T-47200	Ulnar Artery

C.11. CID (SELCID-2) Upper Extremity Arteries(unilateral)

CSD	CV	Code Meaning
SRT	T-46010	Innominate Artery

C.12. CID (12108) Upper Extremity Veins

CSD	CV	Code Meaning
SRT	T-49110	Axillary vein
SRT	T-48052	Basilic vein

CSD	CV	Code Meaning
SRT	T-46421	Common Hepatic Artery
SRT	T-46422	Proper Hepatic Artery
SRT	T-46460	Splenic Artery
SRT	T-46510	Superior Mesenteric Artery
MRUS	C12120-1	Superior Mesenteric Artery/Aorta velocity ratio
MRUS	C12120-1	Celiac Artery/Aorta velocity ratio

C.16. CID (12114) Abdominal Veins (unilateral)

CSD	CV	Code Meaning
SRT	T-48720	Hepatic Vein
SRT	T-48727	Left Hepatic Vein
SRT	T-48725	Right Hepatic Vein
SRT	T-48726	Middle Hepatic Vein
SRT	T-48810	Portal Vein
SRT	T-48710	Inferior Vena Cava
SRT	T-48890	Splenic Vein
SRT	T-48840	Superior Mesenteric Vein
MRUS	V12114-01	Main Portal Vein

C.17. CID (12115) Renal Vessels

CSD	CV	Code Meaning
SRT	T-46600	Renal Artery
SRT	T-48740	Renal Vein
SRT	T-46659	Segmental Artery
SRT	T-4668A	Arcuate Artery of the Kidney
SRT	T-4667D	Interlobar Artery of Kidney
MRUS	V12115-01	Main Renal Artery
LN	33869-9	Renal Artery/Aorta velocity ratio

C.18. CID (12116) Vessel Segment Modifiers

CSD	CV	Code Meaning
SRT	G-A119	Distal
SRT	G-A188	Mid-longitudinal
SRT	G-036A	Origin of vessel



M7 Series Diagnostic Ultrasound System

CSD	CV	Code Meaning
SRT	G-A118	Proximal
SRT	R-1025B	Dilated portion of segment

C.19. Mapping be2186 6085.3f 1730 60986 6085.3f 1730 6SL. 8.33333 0 0

ICA	T-45300,SRT,Internal Carotid Artery
Subclav A	T-46100,SRT,Subclavian Artery
Vert A	T-45700,SRT,Vertebral Artery

C.19.3. Intracranial Cerebral Vessels

<i>MODALITY Label</i>	<i>DICOM Mapping</i>
ACA	T-45540,SRT,Anterior Cerebral Artery
MCA	T-45600,SRT,Middle Cerebral Artery
PCA	T-45900,SRT,Posterior Cerebral Artery
PCoMA	T-45320,SRT,Posterior Communicating Artery

C.19.4. Intracranial Cerebral Vessels (unilateral)

<i>MODALITY Label</i>	<i>DICOM Mapping</i>
BA	T-45800,SRT,Basilar Artery
ACoMA	T-45530,SRT,Anterior Communicating Artery
Ba V	V12106-01,MRUS,Basilar Vein

C.19.5. Upper Extremity Arteries

<i>MODALITY Label</i>	<i>DICOM Mapping</i>
Axill A	T-47100,SRT,Axillary Artery
Brachial	T-47160, SRT, Brachial Artery
Radial A	T-47300,SRT,Radial Artery
Subclav	T-46100, SRT, Subclavian Artery
Ulnar A	T-47200,SRT ,Ulnar Artery

C.19.6. Upper Extremity Arteries(unilateral)

<i>MODALITY Label</i>	<i>DICOM Mapping</i>
Innom A	T-46010, SRT, Innominate Artery

C.19.7. Upper Extremity Veins

<i>MODALITY Label</i>	<i>DICOM Mapping</i>
Axill V	T-49110,SRT ,Axillary vein
Basilic V	T-48052,SRT,Basilic vein
Brachial V	T-49350,SRT,Brachial vein

Cephalic V	T-49240,SRT,Cephalic vein
Radial V	T-49340,SRT,Radial vein
Subclav V	T-48330,SRT,Subclavian vein
Ulnar V	T-49330,SRT,Ulnar vein

C.19.8. Lower Extremity Arteries

<i>MODALITY Label</i>	<i>DICOM Mapping</i>
C.Iliac A	T-46710,SRT,Common Iliac Artery
A.Tib A	T-47700,SRT ,Anterior Tibial Artery
CFA	T-47400,SRT ,Common Femoral Artery
Dors.Ped A	T-47741,SRT,Dorsalis Pedis Artery
Ex.Iliac A	T-46910,SRT ,External Iliac Artery
IIA	T-46740,SRT ,Internal Iliac Artery
Peroneal A	T-47630,SRT ,Peroneal Artery
Pop A	T-47500,SRT ,Popliteal Artery
P.Tib A	T-47600,SRT ,Posterior Tibial Artery
PFA	T-47440,SRT ,Profunda Femoris Artery
SFA	T-47403 ,SRT ,Superficial Femoral Artery
TP Trunk A	V12109-01,MRUS,TP Trunk Artery

C.19.9. Lower Extremity Veins

<i>MODALITY Label</i>	<i>DICOM Mapping</i>
A.Tib V	T-49630,SRT,Anterior Tibial Vein
CFV	G-035B,SRT,Common Femoral Vein
C.Iliac V	T-48920,SRT,Common Iliac Vein
Ex.Iliac V	T-48930,SRT,External Iliac Vein
Sural V	T-4942D,SRT,Gastrocnemius vein
Saph V	T-49530,SRT,Great Saphenous Vein
SSV	T-49550,SRT,Lesser Saphenous Vein
Peroneal V	T-49650,SRT,Peroneal Vein
Pop V	T-49640,SRT,Popliteal Vein
P.Tib V	T-49620,SRT,Posterior Tibial Vein
PFV	T-49660,SRT,Profunda Femoris Vein
Soleal V	G-036B,SRT,Soleal vein
SFV	G-035A,SRT,Superficial Femoral Vein

IIV	T-48940,SRT,Internal iliac vein
Femoral V	T-49410,SRT,Femoral vein
TP Trunk V	V12110-01,MRUS,TP Trunk Vein

C.19.10. Abdominal Arteries (unilateral)

<i>MODALITY Label</i>	<i>DICOM Mapping</i>
Abdominal Aorta	T-42000,SRT,Aorta
Celiac Axis	T-46400,SRT,Celiac Axis
C Hepatic A	T-46421,SRT,Common Hepatic Artery
Hepatic A	T-46422,SRT,Proper Hepatic Artery
Splenic A	T-46460,SRT,Splenic Artery
SMA	T-46510,SRT,Superior Mesenteric Artery

C.19.11. Abdominal Veins (unilateral)

<i>MODALITY Label</i>	<i>DICOM Mapping</i>
Hepatic V	T-48720,SRT,Hepatic Vein
Left Hepatic V	T-48727,SRT,Left Hepatic Vein
Right Hepatic V	T-48725,SRT,Right Hepatic Vein
M Hepatic V	T-48726,SRT,Middle Hepatic Vein
Portal V	T-48810,SRT,Portal Vein
IVC	T-48710,SRT,Inferior Vena Cava
Splenic V	T-48890,SRT,Splenic Vein
SMV	T-48840,SRT,Superior Mesenteric Vein
M Portal V	V12114-01,MRUS,Main Portal Vein

C.19.12. Renal Vessels

<i>MODALITY Label</i>	<i>DICOM Mapping</i>
Ren A Org	T-46600,SRT,Renal Artery
Renal A	T-46600,SRT,Renal Artery
Renal V	T-48740,SRT,Renal Vein
Segment A	T-46659, SRT, Segmental Artery
Arcuate A	T-4668A, SRT, Arcuate Artery of the Kidney
Interlobar A	T-4667D, SRT, Interlobar Artery of Kidney
M Renal A	V12115-01, MRUS, Main Renal Artery



M7 Series Diagnostic Ultrasound System
